

FAR TOOLS®

FR	Rénovateur compact (Notice originale)
EN	Compact renovator (Original manual translation)
DE	Kompakter Renovierung (Übersetzung aus dem Original-Anleitung)
ES	Renovador compacto (Traducción del manual de instrucciones originale)
IT	Rinnovatore compatto (Traduzione dell'avvertenza originale)
PT	Renovador compacto (Tradução do livro de instruções original)
NL	Compacte renovatie (Vertaling van de originele instructies)
EL	ΣΥΜΠΑΓΗΣ ΑΝΑΚΑΙΝΙΣΤΗ (ΜΕΤΑΦΡΑΣΗ ΑΠΟ ΤΙΣ ΠΡΩΤΟΤΥΠΕΣ ΟΔΗΓΙΕΣ)
PL	Kompaktowy remont (Tłumaczenie z oryginalnej instrukcji)
FI	Kompakti remontoija (Käännös alkuperäisestä ohjeet)
SV	Kompakt renoverare (Översättning från originalinstruktioner)
BU	Компактен ремонт (Превод на оригиналната инструкция)
DA	Kompakt reovering (Oversættelse fra oprindelige brugsanvisning)
RO	Renovator compact (Traducere din instrucțiunile originale)
RU	Компактный ремонт (Перевод с оригинальной инструкции)
TU	Kompakt renovator (Orijinal talimatlar çeviri)
CS	Kompaktní restaurátor (Překlad z originálního návodu)
SK	Kompaktný reštaurátor (Preklad z originálneho návodu)
HE	בקמ שיטפ (שיפוץ קומפקטי)
AR	آلة إصلاحات تامل عملتلا نم قم جرتلا (آلة صيدم ديديج)
HU	Felújító kompakt (Fordítás az eredeti utasítások)
SL	Obnovitelj Kompakten (Prevod iz izvirnih navodil)
ET	Renoveerija kompaktne (Tõlge originaal juhiseid)
LV	Renovators kompakts (Tulkojumā no instrukcijas oriģinālvalodā)
LT	Renovatorius kompaktiškas (Vertimas iš originalių instrukcijas)
HR	Renovator kompaktni (Prijevod prema originalne upute)



REX 80
Professional Machine



© FAR GROUP EUROPE



115018-Manual-D-20220317



www.fartools.com



VIDEO DÉMONSTRATION DEMONSTRATION

Flashez le code ci contre,
ou rendez vous sur l'adresse suivante :

Flash the code below,
or go to the following address:



<https://www.fartools.com/r-novateur-compact-boutique-1700-1701-0-6687.html#gallery-photo-2>

MERCI !



En choisissant ce rénovateur compact **FARTOOLS**, vous permettez d'en diminuer l'impact **environnemental** !

En retravaillant l'emballage, nous avons supprimé **61 %** des produits dérivés des hydrocarbures.

Cette opération a ainsi permis **d'abaisser son émission de gaz à effet de serre** :

- **il utilise moins de ressources naturelles,**
- **son volume transporté est nettement plus faible.**

>>> Pour en savoir plus, flashez ce code
et retrouvez toutes les informations sur notre site :



Description et repérage des organes de la machine
 Description and location of machine parts

A

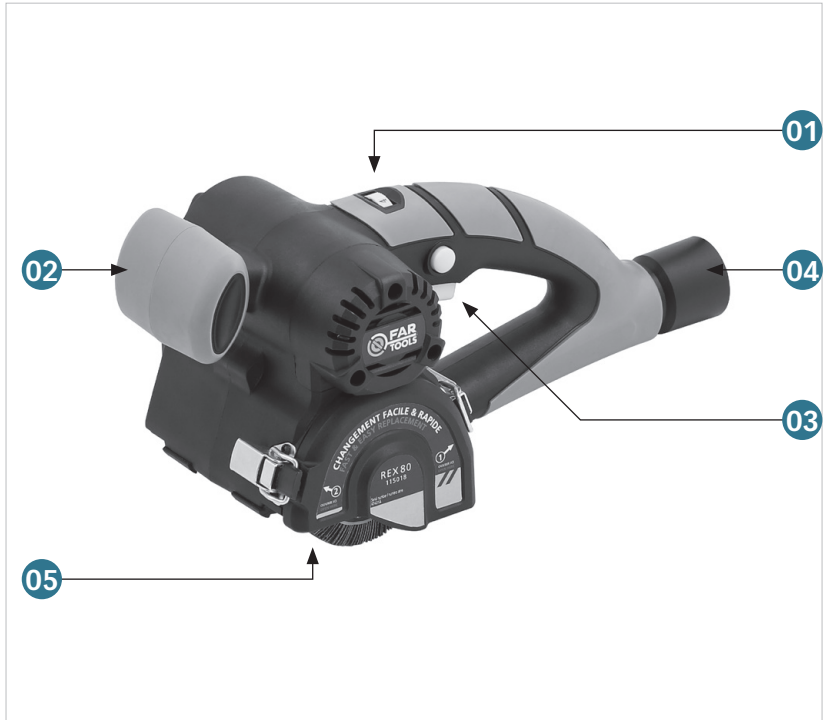

Contenu du carton
 Contents of box

C



FR
 Éléments d'emballage



FR
 Cet appareil et ses accessoires se recyclent



Points de collecte sur www.quefairemedesdechets.fr
 Privilégiez la réparation ou le don de votre appareil !

D

02

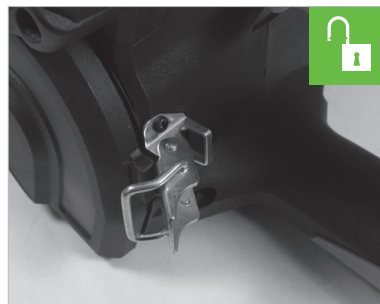
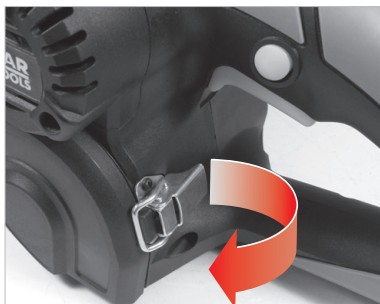
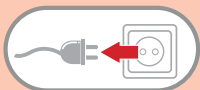

03

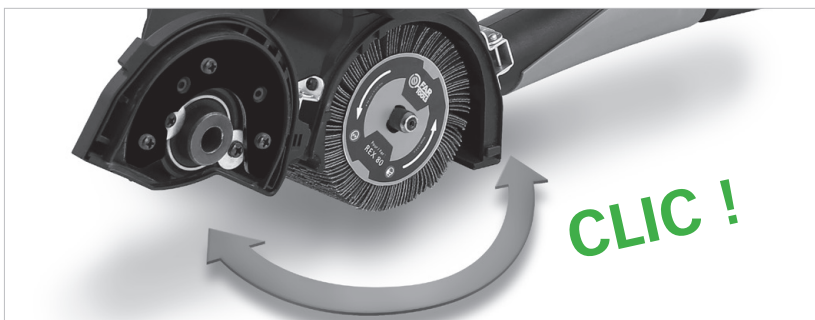
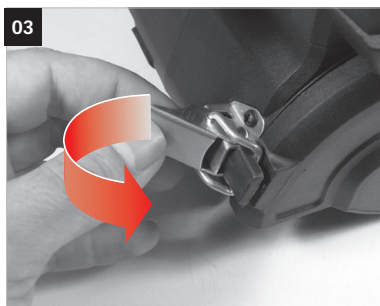

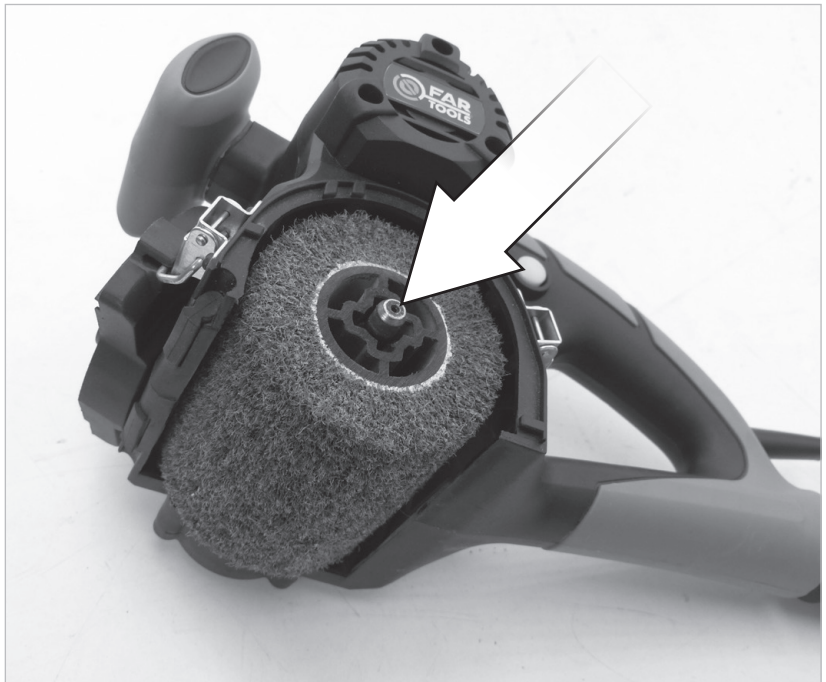
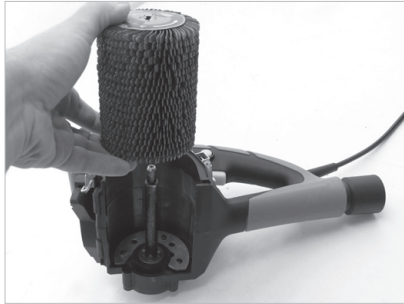
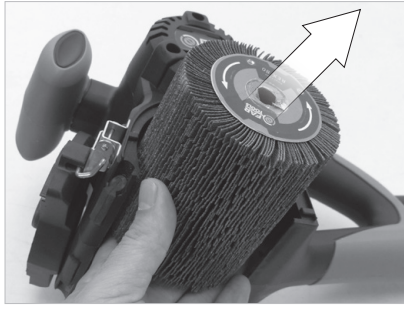



Fonctionnalité de la machine
Functions of the machine

E

01

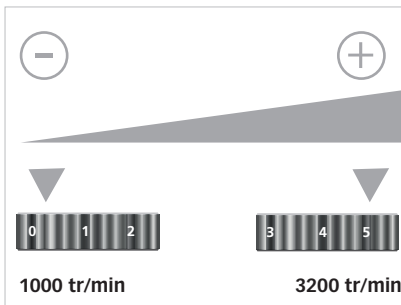
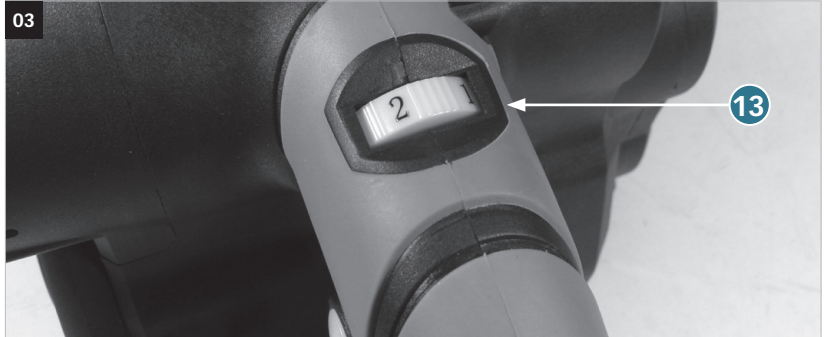
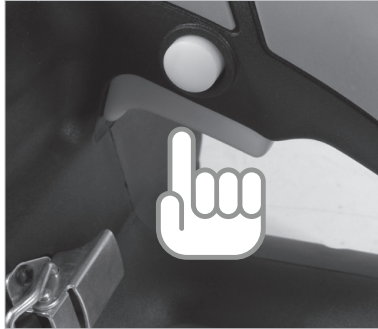
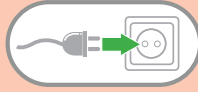

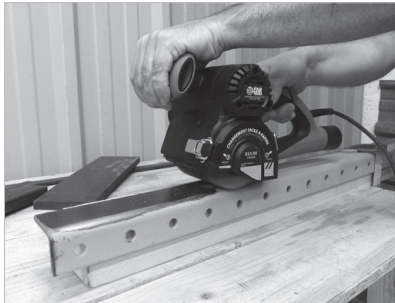
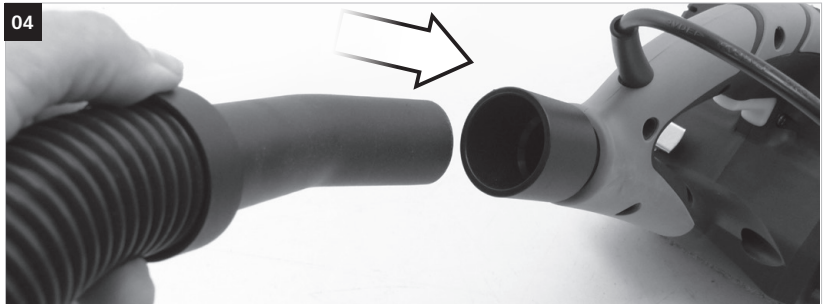

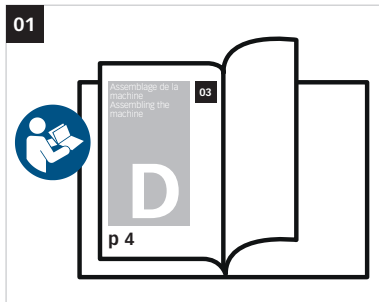

Option - Option - Option - Opcional - Opzione - Opção - Opție - Επιλογή - Opcja - Valinnainen - Tillval - **Допълнително** - Ekstra udstyr - Opcjone - **Оптация** - seçenek / seçim Volba - Волба - הציפור - رايوتج - Opció - Možnost - Valik - Opcija - Izvleče



110891:
Brosse fil laitonnée 0,3 mm
Staalborstel messing 0,3 mm
0,3 mm cepillo de alambre de latón
0,3 milímetros escova de arame de bronze
0,3 milimetri spazzola metallica di ottone
0.3 mm brass wire brush



110892:
Brosse Nylon avec fil enrobé d'abrasif
Nylon gecoatete draad borstel met schurende
Cepillo de alambre revestido de nylon con abrasivos
Escova de fio de nylon revestido com abrasivo
Spazzola di filo rivestito in nylon con abrasivo
Nylon coated wire brush with abrasive

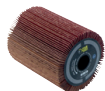

110893:
Brosse à lamelles
Flap Brush
Solapa cepillo
Escova Flap
Spazzola Flap
Flap Brush



110894:
Brosse fibre synthétique
Synthetische vezel penseel
Pincel de fibra sintética
Escova de fibra sintética
Pennello in fibra sintetica
Synthetic fiber brush





110910:
Brosse coton
Katoenen borstel
Cepillo de algodón
Escova de algodão
Spazzola di cotone
Cotton brush



110911:
Brosse carbure de silicium
Siliciumcarbide borstel
Cepillo de carburo de silicio
Escova de carboneto de silicio
Spazzola in carburo di silicio
Silicon carbide brush

	<p>Tension et fréquence assignée: Nominal frequency and power: Spannung und Frequenz: Tensión y frecuencia fijada: Tensione e frequenza assegnata: Tensão e frequência fixa: Aangewezen spanning en frequentie: ΟΝΟΜΑΣΤΙΚΗ ΤΑΣΗ ΚΑΙ ΣΥΧΝΟΤΗΤΑ: Napięcie i częstotliwość przydzielona: Jännite ja määrittäyty taajuus: Angiven spänning och frekvens: Anført spænding og frekvens: Tensiune și frecvență de lucru:</p>	<p>Заданное напряжение и частота: Tahsis gerilimi ve frekansı: Stanovené napětí a frekvence: Stanovené napätie a frekvencia: מחמת ומדר מוקצב الفلطية والذبذبة الجبرمجة. Névfleges feszültség és frekvencia: Napetost in določena frekvenca: Консумирано напрежение и честота : Määratud pinge ja sagedus Nustatyta įtampa ir dažnis Noteiktāis spriegums un frekvence. Napon i nazivna frekvencija:</p>	<p>230 V ~ 50 HZ</p>
---	---	--	----------------------

	<p>Puissance assignée: Nominal power: Leerlaufdrehzahl: Potencia fijada: Potenza assegnata: Potência assinada: Onbelast toerental: ΟΝΟΜΑΣΤΙΚΗ ΙΣΧΥΣ: Prędkość na biegu jałowym: Teho: Angiven effekt: Anført styrke: Putere de lucru:</p>	<p>Заданная мощность: Tahsis edilen güç: Stanovený příkon: Predpísaný výkon: כוח מוקצב. القدرة الجبرمجة. Névfleges teljesítmény : Določena jakost: Консумирана мощност: Määratud võimsus. Nustatyta galia Noteiktā jauda Nazivna snaga:</p>	<p>420 W</p>
---	---	--	--------------

	<p>Classe d'isolement : 2 Insulation class : 2 Isolierung klasse : 2 Aislamiento clase :2 Isolamento classe :2 Isolamento classe :2 Isolatie Klasse : 2 ΚΑΤΗΓΟΡΙΑ ΜΟΝΩΣΗΣ: 2 Izolacja Klazy :2 Eristysluokka :2 Isolering Klass :2 Isoleringsklasse 2 Clasă izolație :2</p>	<p>Класс изоляции 2 : Yalitim derecesi :2 Třída izolace :2 Izolačný systém 2 סוג בידוד :2 فئة العزل :2 Szigetelési osztály :2 Razred izolacije :2 Инструмент Клас :2 Isolatsiooniklass 2 Izolācijas rūšis 2 Izolācijas klase 2 Izolacija klasa :2</p>	<p>X</p>
--	---	--	----------





	<p>Vitesse à vide: No-load speed: Drehzahl unbelastet: Velocidad vacía: Velocità a vuoto: Velocidade no vácuo: Leerlaufdrehzahl: ΤΑΧΥΤΗΤΑ ΑΔΡΑΝΕΙΑΣ: Prędkość bez bciążenia: Tyhjäkäyntinopeus Tomgångshastighet: Hastighed i ubelastet tilstand: Viteza în gol:</p>	<p>Скорость вращения на холостом ходу: Boşalma hızı: Rychlost naprázdno: Rychlost pri chode naprázdno: מהירות ריק. السرعة على الفارغ. Üres sebesség: Prosti tek: Скорост на празни обороти: Kiirus tühikäigul Tuščio prietaiso greitis Tukšgaitas ātrums Brzina praznog hoda:</p>	<p>1000-3200 min⁻¹</p>
---	--	--	-----------------------------------

	Porter des lunettes de sécurité : Wear protective eyewear : Schutzbrille tragen : Llevar puestas gafas protectoras : Portare de gli occhiali di sicurezza : Utilizar óculos de segurança : Draag een veiligheidsbril : ΦΟΡΑΤΕ ΠΡΟΣΤΑΤΕΥΤΙΚΑ ΓΥΑΛΙΑ: Zakładać okulary ochronne : Käytä suojalaseja : Använd skyddsglasögon : Der skal benyttes sikkerhedsbriller : Purtati ochelari de protectie :	Наденьте защитные очки : Güvenlik gözlükleri takın : Používejte bezpečnostní brýle : Noste ochranné okuliare : תחמיטב פקטמ ביכרהל אנ חמל נפזרות וקאי. Viseljen védőszemüveget : Nositi zaščitna očala : Да се използват защитни очила : Kandke kaitseprille Nešioti apsauginius akinius Valkät aizsargbrilles Nositi zaštitne naočale:	X
---	---	--	---

	Porter un masque anti-poussière : Wear a dust mask : Staubschutzmaske tragen : Llevar puesta una careta de protección contra el polvo : Indossare una mascherina anti-polvere : Utilizar uma máscara anti-poeira : Draag een stofmasker : ΧΡΗΣΗ ΠΡΟΣΤΑΤΕΥΤΙΚΗΣ ΜΑΣΚΑΣ : Zakładać maskę przeciwpylową Käytä pölysuojust : Bär mask mot damm : Der skal benyttes beskyttelsesmaske mod støv: Purtati mască anti-praf :	Наденьте респиратор : Toza karşı maske takın : Používejte masku proti prachu : Noste ochrannú masku proti prachu : קבא דגנ הכסמ שובבל אנ لبس قزاز مضاض للغباز. Viseljen porvédő maszkot Nositi zaščitno masko proti prahu: Да се използва защитна маска : Kandke tolmmaski. Dévétí respiratorių Valkät aizsarg masku pret putekļiem Nositi masku za zaštitu od prašine:	X
---	--	---	---

	Porter une protection auditive : Wear hearing protective equipment: Gehörschutz tragen: Llevar puesta una protección auditiva: Portare una protezione uditiva: Utilizar uma protecção auditiva: Draag gehoorbeschermers: ΦΟΡΑΤΕ ΠΡΟΣΤΑΣΙΑ ΑΚΟΗΣ: Zakładać słuchawki ochronne Käytä kuulosuojaimia: Bär hörselskydd: Der skal benyttes høreværn: Purtati căști de protectie auz:	наденьте средства звуковой защиты: İşitsel koruma aleti takın: Používejte ochranu sluchu: Noste ochranné slúchadlá: יש ל הרכיב הגנת שמיעה لبس خبذة ضوضاء الخرجى ج Viseljen fülvédőt Nositi zašito ušes: Да се използва слухови защитни средства: Kandke kõrvakaitset Nešioti apsaugą nuo triukšmo Valkät dzirdes aizsarglīdzekli Nositi štitnike protiv buke:	X
--	---	---	---

	Porter des gants : Use rubber gloves : Schutzhandschuhe tragen : Llevar guantes de protección : Indossare i guanti di protezione : Utilizar luvas de protecção : Draag veiligheidshandschoenen : ΧΡΗΣΗ ΠΡΟΣΤΑΤΕΥΤΙΚΩΝ ΓΑΝΤΙΩΝ : Używać rękawic ochronnych : Käytä suojakäsineitä : Använd skyddshandskar : Der skal benyttes handsker : Purtati mănuși :	Наденьте перчатки : Eldiven takın : Noste rukavice : Noste rukavice : תופכב שובבל אנ لبس قفازات. Viseljen kesztyű t Nositi rokavice: а се използват предпазни ръкавици : Kandke kindaid Mūvēti pirštines Valkät cimds Nositi zaštitne rukavice:	X
---	--	---	---

	<p>Lire les instructions avant usage : Read the instructions before use : Vor Einsatz des Geräts Anweisung lesen : Léase las instrucciones antes de usar : Leggere le istruzioni prima dell'uso : Ler as instruções antes da utilização : Lees voor het gebruik de instructies : ΔΙΑΒΑΣΤΕ ΤΙΣ ΟΔΗΓΙΕΣ ΠΡΙΝ ΑΠΟ ΤΗ ΧΡΗΣΗ: Zapoznać się instrukcją przed użyciem : Lue ohjeet ennen käyttöä : Läs anvisningarna före användning : læs instruktionerne før brug Înainte de utilizare, cititi instructiunile :</p>	<p>Внимательно прочитайте следующие инструкции : Kullanmadan talimatları okuyunuz : Pozorně si přečtete následující pokyny : Pred použitím si prečítajte pokyny : זרם חילופי اقرأ التعليمات قبل الاستخدام. használat előtt olvassuk el az utasítást : Pred uporabo preberite ustrezna navodila Прочетете указанията за употреба : Enne kasutamist lugege instruksiooni Prieš naudojimą perskaityti instrukciją izlasīt instrukcijas pirms lietošanas Pročitati upute prije uporabe:</p>	<p>X</p>
	<p>Conformité européenne CE Conforms to EC standards : CE-Konformität : Cumple con las directivas CE : Conforme alle norme CE : Conforme às normas CE : Voldoet aan de EG-normen : ΕΥΡΩΠΑΪΚΗ ΣΥΜΜΟΡΦΩΣΗ CE Zgodność z normami CE : EU-standardien mukainen : EU-standardien mukainen : Overholder EU standarderne : Conform cu normele europene:</p>	<p>соответствие европейским стандартам : Avrupa uygunluk : evropská shoda : európska dohoda : התאמה לתקנים האירופיים مطابق للخواصفات الأوروبية. európai megfelelőség : Съответствие с европейските норми : Euroopa Liidu vastavusmärk Europinių normų atitikima Atbilstība Eiropas standartiem Evropska sukladnost</p>	<p>X</p>
	<p>Danger : Danger : Gefahr : Peligro : Pericolo : Perigo : Gevaar : ΚΙΝΔΥΝΟΣ: Niebezpieczeństwo : Vaara : Fara : Fare : Pericol :</p>	<p>Опасно : Tehlike : Nebezpečí : Nebezpečstvo : סכנה. خطر. Veszély : Nevarnost: Опасно : Oht Pavojus Bistamība Opasnost:</p>	<p>X</p>
	<p>Poids : Weight : Gewicht : Peso : Peso : Peso : Gewicht : ΒΑΡΟΣ : Masa : Paino : Vikt : Vægt : Greutate :</p>	<p>Вес : Ağırlık : Hmotnost : Hmotnosť : משקל الوزن. Súly : Teža : Тегло : Raskus Svoris Svars Težina</p>	<p>2,7 kg</p>

 L_{pA}	Niveau de pression acoustique : Acoustic pressure level : Schalldruckpegel : Nivel de presión acústica : Livello di pressione acustica : Nivel de pressão acústica : Niveau akoestisch druk : ΣΤΑΘΜΗ ΗΧΗΤΙΚΗΣ ΠΙΕΣΗΣ: Poziom mocy akustycznej : Käytä kuulosuojaimia: Ljudtrycksnivå : Lydtryk : Nivel presiune acustică :	Уровень акустического давления. : Akustik basınç seviyesi : Hladina akustického tlaku : Hladina akustického tlaku : רמת לחץ אקוסטי. مستوى الضغط السمعي. A hangnyomás szintje : Nivo akustičnega pritiska: Равнище на акустично налягане : Helirõhu nivoo Akustinio spaudimo lygis Akustiskā spiediena līmenis Razina zvučnog tlaka:	87 dB (A)

 L_{wA}	Niveau de puissance acoustique : Acoustic power level : Schalleistungspegel : Nivel de potencia acústica : Livello di potenza acustica: Nivel de potência acústica: Niveau akoestisch vermogen : ΕΠΙΠΕΔΟ ΙΣΧΥΟΣ ΉΧΟΥ: Poziom mocy akustycznej : Käytä suojalaseja : Ljudstyrkenivå : Lydstyrke : Nivel putere acustică :	уровень мощности звука : Akustik basınç seviyesi : Hladina zvukového výkonu: Hladina zvukového výkonu: רמת כוח אקוסטי. مستوى الخرجي. a hangnyomás szintje : Nivo akustične jakosti : Равнище на вибрации : Helivõimsuse nivoo Triukšmo lygis Akustiskās jaudas līmenis Razina zvučne snage:	98 dB (A)

NIVEAU SONORE D'ÉMISSION :

A VIDE

Pression acoustique LpA poste opérateur
Incertitude

87 dB
3

Puissance acoustique LWA
Incertitude

98 dB
3

Valeurs déterminées suivant le code d'essai de l'annexe B de la norme EN 61029-1 avec emploi des normes de base ISO 11201 et ISO 3744.

Les niveaux de pression acoustique obtenus in situ dépendent:

- Des niveaux réels de la machine considérées, en prenant en compte les incertitudes déclarées;
- Du local et de l'installation de la machine. Préférez une pièce dont l'acoustique est plus feutrée. Evitez les pièces vide à grande résonance. Placez vous auprès d'une fenêtre le cas échéant.
- Des outils montés, des pièces travaillées, des réglages choisis,...

 L_{vA}	Niveau de vibration : Hand/arm vibration level : Vibrationspegel Hand/Arm : Nivel de vibración mano/brazo : Livello di vibrazione mano/braccio : Nivel de vibração mão/braço : Trillingsniveau hand/arm : ΕΠΙΠΕΔΟ ΚΡΑΔΑΣΜΩΝ: Poziom wibracji rżka/ramiż : Tärinätaso: Vibrationsnivå hand/arm : Vibrationsniveau : Nivel vibratii :	Уровень вибрации : Titreşim seviyesi : Úroveň vibrací : Hladina vibrácií : רמת תנודות مستوى الارتجاج. Vibrációs szint : Nivo vibracij : Равнище : Vibrācijas līmenis. Vibrācijas lygis Vibratsiooni nivo Razina vibracije:	14,6 m / s ²

VIBRATIONS:

Total des valeurs de vibration (somme vectorielle des trois directions) déterminée selon EN 60745 :

a

14,6 m/s²

Incertitude K

1,5 m/s²

L'amplitude d'oscillation peut être utilisée comme valeur de comparaison d'outils électroportatifs.

Attention : si l'outil électroportatif est utilisé pour d'autres applications, avec d'autres outils de travail, l'amplitude d'oscillation peut être différente.

	<p>Soumis à recyclage Subjected to recycling Sujeto a reciclaje Sottoposti a riciclaggio Sujeitos a reciclagem Não deite no lixo : Niet wegwerpen : ΜΗΝ ΤΗΝ ΠΙΤΑΤΕ : Nie wyrzucac : Älä heitä pois luontoon : Batteriet får inte kastas : Bortkast det ikke: Nu le auncati :</p>	<p>Не выбрасывайте в мусорный ящик Atmayiniz : Nevyhaziujte je do bežného odpadu : Neodhadzovat : אין לזרוק סלילות فلا ترممها ملندا في القمامة. ne mečite1 Ne odvržite ga/jih vstran : Не го извърляйте : Árge visake seda minema : Nemétykíte : Nemest : Podvrgnuto recikliranju</p>	X
---	--	---	---

Recyclage des déchets :

Les outils, accessoires et leur emballages doivent suivre une voie de recyclage adaptée. Conformément aux directives Européenne 2012/19/UE et 2006/66/CE, les composants d'un produit doivent être séparés, collectés, recyclés ou éliminés en conformité avec les réglementations environnementales en vigueur. Les appareils, batteries, piles, huiles, emballages devront être déposés dans les systèmes d'élimination des déchets spéciaux tels que déchetteries. Renseignez-vous auprès de votre commune pour connaître l'organisme le plus proche à même de retraiter ou de collecter ces déchets.

	<p>Recyclable, soumis au tri sélectif Recyclable, subject to recycling Recyclingfähige, unterliegen Recycling Reciclables, sujetos a reciclaje Riciclabili, soggetti a riciclaggio Recicláveis, sujeito à reciclagem Recycleerbare, onderworpen aan recycling ΑΝΑΚΥΚΛΩΣΙΜΕΣ ΣΥΣΚΕΥΑΣΙΕΣ ΠΟΥ ΥΠΟΚΕΙΝΤΑΙ ΣΕ ΚΥΚΛΩΣΗ Opakowanie nadaje się do recyklingu podlegają recyklingu Kierrätettävien pakkausten kohteena kierrätys Återvinningsbara förpackningar omfattas återvinning Рециклиращи се опаковки подлежат на рециклиране Genanvendelig underlagt genbrug</p>	<p>Reciclabile sub rezerva reciclare Повторно упаковка подлежит вторичной переработке Geri dönüştürme Geri dönüştürülebilir ambalaj konusu Recyklovateľné podléhajúci recyklácii Recyklovateľné podliehajúce recykláciiu רוחמל ורוחמל הזיראה אשור ريوندتلا هدا اعال يرضح ريوندتلا هدا اعال هدا اول اقول فحل و فحل و فحل Újrahasznosítható csomagolás alá újrahasznosítás Reciklirati predmet recikliranje Pakendite suhtes ringlussevõtu Pärstrådājams iepakojuoms atreizējai pārstrādei Perdirbamų taikomos perdirbimo Može se reciklirati, podložno selektivnomu sortiranju</p>	X
---	---	--	---

	<p>Diamètre de brosse et largeur : Diameter of wheel and width : Bürstendurchmesser und Breite : Cepillar diámetro y anchura: Escovar diâmetro e largura: Spennellare diametro e larghezza: Borstel diameter en breedte: ΔΙΑΜΕΤΡΟ ΔΙΣΚΟΥ : Srednica tarczy i otwór : Leikkuuterän läpimitta ja kalviminen : Skivens diameter och innerdiameter : Skivens ydre og indre diameter : Diametru disc si alezaj :</p>	<p>Диаметр диска и пропила : Disk ve delik çapı : Průměr kotouče a vrtání : Priemer kotúča a vnútorný priemer : קטר הדיסקה וקידוד قطر الأسطوانة والتجويف A tárcsa és a furat mérete : Premer diska in izvrtine : Диаметър на резаца : Ketta ja puurimise diameeter : Skersmuo : Diska un caurplūdes atvērums diametrs : Promjer četke i širina:</p>	ø 80 x 100 mm
---	---	--	---------------

REX 80

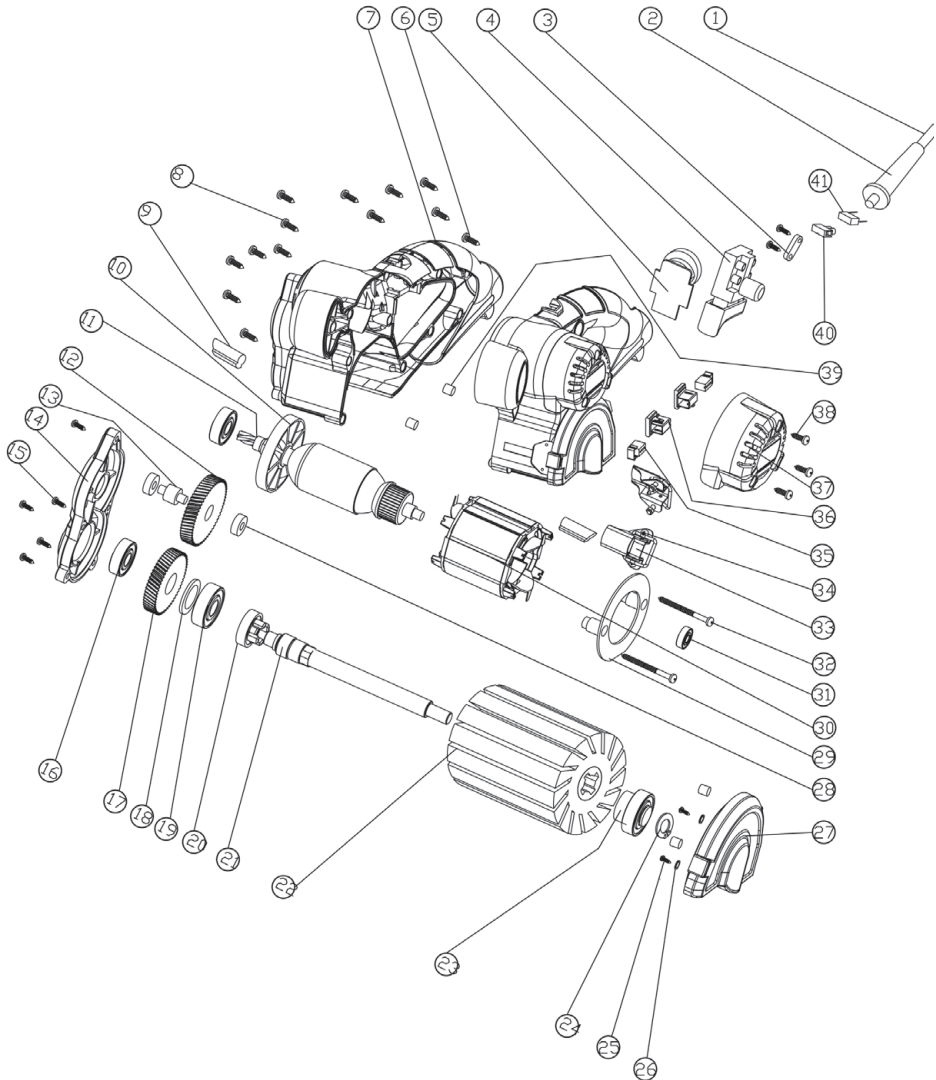

DECLARATION DE CONFORMITE
VERKLARING VAN OVEREENSTEMMING
DECLARACION DE CONFORMIDAD
DICHIARAZIONE DI CONFORMITA
KONFORMITÄSERKLÄRUNG
DECLARATION CONFORMITY
DECLARAÇÃO DE CONFORMIDADE
DEKLARACJA ZGODNOSCI Z NORMAMI
OM ÖVERENSSTÄMMELSE
VAATIMUSTENMUKAISUUSVAKUUTUS
OVERENSSTEMMELSESERKLÆRING
ΔΗΛΩΣΗ ΣΥΜΜΟΡΦΩΣΗΣ

DECLARAȚIE DE CONFORMITATE
VYHLÁSENIE ZHODY
Декларация соответствия
הצהרת תואמת
Uygunluk beyanı
التصريح بالامتثال
PROHLÁŠENÍ SHODY
EGYZESÉGI NYILATKOZAT
Декларация за съответствие с нормите
IZJAVA O SKLADNOSTI
DEKLARACIJA
ATITIKTIES DEKLARACIJA
KINNITUS
IZJAVA O SUKLADNOSTI

Le soussigné,
Ondergetekende,
Der Unterzeichner,
O abaixo assinado,
Undertecknad,
Долуподписаният
Undertegnede
Subsemnatul,
Я, нижеподписавшийся,
Imzalayan,
Niže podepsany,
Tollau pasirasęs

Déclare par la présente que,
Verklaart hiermede dat,
Erklärt hiermit daß,
Declara pela presente que,
Förklarar härmed att
Заявляя с настоящото
erklærer hermed, at
Declar prin prezenta că,
настоящим подтверждаю, что
Mevcut belgeyle beyan ediliyor ki,
tımto prohlasuje, že,
Pareiskia, kad,

Personne autorisée à constituer
le dossier technique :
Ronan GUILLIOT



FAR GROUP EUROPE
192, Avenue Yves Farge
37700 St. Pierre-des-Corps
FRANCE

El suscrito,
Il sottoscritto,
The undersigned,
Ninej podpisany
Allekirjoittanut,
Ο ΚΑΤΩΘΙ ΥΠΟΓΡΑΦΜΕΝΟΣ,
Nizšie podpisany
החתום מטה
الذوق أعيناه
Alulírott,
Podpisani,
Apakša parakstijies
allakirjutanu
Dolje potpisani,

Declara por la presente, que,
Dichiare che,
Declares that,
Oświadczam niniejszym, że
Ilmoittaan täten että,
ΔΙΑ ΤΟΥ ΠΑΡΟΝΤΟΣ ΔΗΛΩΝΕΙ ΟΤΙ,
tymto vyhlasuje, že
מצהיר בה כן
يصرح استنادا على ذلك
kijeleltem, hogy a készülék Izjavlja da,
Pareiskia, kad,
Ar šo apliecinā, ka,
Kinnitab, et
izjavljuje u ovom dokumentu da je

Rénovateur compact / Compact renovator / Kompakter Renovierung / Renovador compacto / Rinnovatore compatto / Renovador compacto /
Compacte renovatie / ΣΥΜΠΛΗΡΗΣ ΑΝΑΚΑΙΝΙΣΤΗ / Kompaktowy remont / Kompakti remontoija / Kompakti renoverare / КОМПАКТЕН РЕМОНТ /
Kompakt renovering / Renovator compact / Компактный ремонт / Kompakt renovator / Kompaktini restaurātor / Felújító kompakt / Obnovitelj
Kompakten / Renoveerija kompaktnie / Renovators kompakts / Renovatorius kompaktiškas / Renovator kompaktni

code

FARTOOLS / 115018 / REX 80 / JD2676

Est conforme et satisfait aux directives et normes CE,
In overeenstemming is met en Voldoet aan EG richtlijnen,
Den folgenden EU-Bestimmungen entspricht,
Respeita e está em conformidade com as normas CE,
Överensstämmer med och uppfyller EG-standarder,
Съответства и отговаря европейските норми
Er i overensstemmelse med og overholder EU standarderne
Este conform și satisfacă normele CE
полностью соответствует и удовлетворяет
требованиям стандартов ЕС
CE şartlara uygundur,
odpovídá normám ES.
Atitinka ir atitinka EB direktyvas ir standartus,

Cumple con la directivas de la CE,
E conforme alle direttive CEE,
Complies with the EEC directives and standards,
Odpowiada normom UE,
Täyttää EU-vaatimukset,
zodpovedá normám ES.
מתאים ועונה לתקני CE
بان الحوازي مطابق و يلقى معايير مجموعة الدول الأوروبية
kielegíti a CE szabványok előírásait.
Je v skladu z in izpolnjuje norme Evropske skupnosti.
Atbilst un atbilst EK direktīvas un standartus.
Vastab ja vastab EU direktīvidele ja standarditele,
Sukladan i ispunjava direktive i standarde CE,

2014/30/EU MD :2006/42/EC 2015/863/EU
2011/65/EU

EN55014-1:2017
EN55014-2:2015
EN61000-3-2:2014
EN61000-3-3:2013
EN62841-1:2015
EN62841-2-4:2014

Ronan GUILLIOT,
Directeur général
08/11/2019
Fait à St. Pierre-des-Corps



115018-Sticker-04-A-Logo.indd 1 28/02/2020 14:42

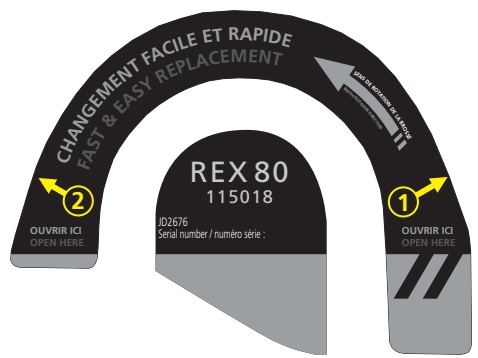
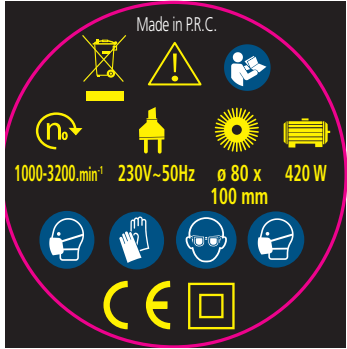

GARANTIE - WARRANTY



FR. GARANTIE

Cet outil est garanti contractuellement contre tout vice de construction et de matière, à compter de la date de vente à l'utilisateur et sur simple présentation du ticket de caisse. La garantie consiste à remplacer les parties défectueuses. Cette garantie n'est pas applicable en cas d'exploitation non conforme aux normes de l'appareil, ni en cas de dommages causés par des interventions non autorisées ou par négligence de la part de l'acheteur. La garantie ne s'applique pas sur les dommages causés par une défaillance de l'outil.

DE. GARANTIE

Die Garantiezeit für dieses Gerät in bezug auf Konstruktions- und Materialfehler beträgt lt. Vertrag bei Vorlage des Kassensbons. Die Garantieleistung besteht im Ersatz schadhafter Teile. Die Garantie erlischt bei einem Einsatz des Geräts, der nicht normentsprechend ist, bei Schäden, die auf unsachgemäße Eingriffe zurückzuführen sind bzw. bei Nachlässigkeit seitens des Käufers. Die Garantie erstreckt sich nicht auf Schäden, die auf Fehlfunktionen des Geräts zurückzuführen sind.

IT. GARANZIA

Quest' attrezzo è garantito per contratto contro qualsiasi difetto di costruzione e di materia, a partire dalla data di vendita all'utente e su semplice presentazione dello scontrino. La garanzia consiste nel sostituire le parti difettose. Questa garanzia non è applicabile in caso di sfruttamento non conforme alle norme dell'apparecchio, né in caso di danni causati da interventi non autorizzati o da negligenza da parte dell'acquirente. La garanzia non si applica ai danni causati da un'avarìa dell'attrezzo.

EN. GARANTIE

This tool is guaranteed, in writing, against any defect in manufacture or parts from the date of sale, upon simple presentation of the sales slip. The guarantee is limited to the replacement of faulty parts. This guarantee is not applicable in the event of usage which is not conform with the intended usage of the apparatus, nor in the event of damage caused by unauthorised servicing or negligence on behalf of the purchaser. This guarantee does not apply to any damage caused by the failure of this tool.

ES. GARANTIA

Esta herramienta se garantiza contractualmente contra todo defecto de construcción y materia, a partir de la fecha de venta a l' usuario y sobre simple presentación del recibo de caja. La garantía consiste en sustituir a las partes defectuosas. Esta garantía no es aplicable en caso de explotación no conforme a las normas

del aparato, ni en caso de daños causados por intervenciones no autorizadas o por negligencia por parte del comprador. La garantía no se aplica sobre los daños causados por un fallo del herramienta.

NL. GARANTIE

Dit gereedschap heeft een garantie tegen constructiefouten en materiaaldefecten, die geldig is vanaf de aankoopdatum door de gebruiker, op vertoning van de kassabon. De garantie betreft de vervanging van de defecte onderdelen. Deze garantie is niet van toepassing indien het apparaat niet volgens de normen gebruikt is, noch in geval van schade veroorzaakt door oneigenlijk gebruik of nalatigheid van de koper. De garantie is niet van toepassing op schade voortvloeiend uit een defect van het gereedschap.

PT. GARANTIA

Esta ferramenta tem uma garantia contratual contra qualquer defeito de construção e de material, a partir da data de venda ao utilizador e sobre simples apresentação do talão da caixa. A garantia consiste em substituir as partes defeituosas. Esta garantia não é aplicável no caso de exploração não conforme as normas do aparelho, nem em caso de danos causados pelas intervenções não autorizadas ou por negligência da parte do comprador. A garantia não se aplica para os danos causados por uma falha da ferramenta.

EL. ΕΓΓΥΗΧΟΝ

ΤΟ ΕΡΓΑΛΕΙΟ ΑΥΤΟ ΕΦΕΡΕΙ ΣΥΜΒΑΤΙΚΗΝ ΕΓΓΥΗΧΗΝ ΓΙΑ ΟΡΘΟΔΕΗΡΟΤΕ ΕΛΕΑΤΤΩΜΑ ΚΑΤΑΣΚΕΥΗΣ ΑΡΕΟ ΤΗΝ ΗΜΕΡΟΜΗΝΙΑ ΠΕΛΛΗΟΧ ΣΤΟ ΧΡΕΪΣΤΗ. ΜΕ ΑΠΛΗΝ ΠΡΟΣΚΕΟΜΙΣΗ ΤΗΣ ΑΡΕΟΥΟΕΙΗΣ ΑΓΟΡΕΑΣ. Η ΕΓΓΥΗΧΗ ΑΡΟΤΕΛΕΙΤΑΙ ΑΤΤΕΟ ΤΗΝ ΑΝΤΙΚΑΤΑΕΟΤΑΟΗ ΤΥΝ ΕΛΑΤΤΩΜΑΤΙΚΕΥΝ ΤΜΗΜΕΑΤΥΝ. Η ΠΑΡΟΕΥΣΑ ΕΓΓΕΥΗΧΗ ΟΕΝ ΕΥΑΡΜΕΟΖΕΤΑΙ ΣΕ ΠΕΡΙΠΥΣΗ ΧΡΕΪΣΗ ΜΗ ΣΕΥΜΩΥΝΗΣ ΜΕ ΤΑ ΠΡΕΟΤΥΠΑ ΤΗΣ ΣΥΣΚΕΜΗΣ. Η ΣΕ ΠΕΡΙΠΤΥΣΗ ΖΗΜΙΑΣ ΠΟΥ ΠΡΟΚΛΗΪΗΚΕ ΑΡΕΟ ΜΗ ΕΓΚΕΚΡΙΜΕΝΗΝ ΕΡΕΕΜΒΑΣΗ ΑΡΕΟ ΑΜΕΕΛΙΑ ΤΟΥ ΑΓΟΡΑΣΤΕΗ. Η ΕΓΓΕΥΗΧΗ ΖΟΕΝ ΕΥΑΡΜΕΟΖΕΤΑΙ ΣΤΙΖ ΖΗΜΙΑΣ ΠΟΥ ΠΡΟΚΑΛΟΕΥΝΤΑΙ ΑΡΕΟ ΒΛΕΑΒΗ ΤΟΥ ΕΡΓΑΛΕΙΟΥ ΣΤΑΥΡΟΕΙ ΚΕΝΟΕΥ ΔΙΑΣΤΗΜΟΣΠΑΡΕΕΜΒΥΣΜΑ

PL. GWARANCJA

Narzędzie jest objęte gwarancją na wszelkie wady konstrukcyjne i materiałowe, licząc od daty sprzedaży u ytkownikowi i po okazaniu paragonu kasowego. Gwarancja obejmuje wymianę części wybrakowanych. Gwarancja nie znajduje zastosowania w przypadku u ytkowania niezgodnego z normami urzędzenia, ani w przypadku szkód spowodowanych działaniami niedozwolonymi lub zaniedbaniami ze strony nabywcy. Gwarancja nie obejmuje szkód powstałych z powodu upadku urzędzenia.

SV. GARANTI

Detta verktyg har en avtalsenlig garanti mot konstruktions och materialfel, från

och med tidpunkten för användarens inköp och genom uppvisning av kassakvittot. Garantin består i att ersätta de bristfälliga delarna. Denna garanti gäller inte om användningen inte motsvarar apparatens standarder, inte heller vid skador som orsakas av ej tillåtna ingrepp eller på grund av köparens värdsloshet. Garantin gäller inte förskador som orsakats av att verktyget fungerat bristfälligt.

FI. TAKUU

Tämän laitteen takuu on voimassa sopimuksenmukaisesti kattaa kaikki rakennel- ja materiaali- ja osien ostopaivasta kassakuitilla vastaan. Takuu sisältää viallisten osien korvaamisen. Takuu ei korvaa ohjeidenvastaista käyttöä eikä valtuuttamattomien henkilöiden käsitteilyä tai ostajan huolimattomuudesta aiheutuneita vahinkoja. Takuu ei vastaa myöskään toimintahäiriöistä aiheutuneita vahinkoja.

BU. Гаранция

Този инструмент е под договорна гаранция срещу всякакъв дефект в изработката и използваните материали, считано от датата на продажба на потребителя и само срещу представяне на касовата бележка. Гаранционното обслужване се състои в замяна на дефектните части. Настоящата гаранция не е валидна когато апаратът се използва по начин, нанесени от неотторизирани лица, или вследствие на проявена небрежност от страна потребителя. Гаранцията не покрива щети, произтекли вследствие на техническа неизправност на апарата.

DA. GARANTI

Dette værktøj er dækket af en garantikontrakt for konstruktions- og materialefejl, som gælder fra købsdatoen ved visning af kassebonen. Garantien består i at udskifte de defekte dele. Garantien dækker ikke fejl opstået som følge af anvendelse, som ikke overholder standarderne for apparatet, eller skader opstået ved ikke autoriserede indgreb eller sløsethed fra brugerens side. Garantien dækker ikke skader opstået, fordi værktøjet har svigtet.

SERVICE APRÈS VENTE - AFTER SALE SERVICE

FARGROUP EUROPE - 192, Avenue Yves Farge - 37700 St. Pierre-des-Corps - FRANCE

fargroup@fargroup.net

GARANTIE - WARRANTY



RO. GARANTIE

Acest aparat este garantat din punct de vedere contractual împotriva tuturor viciilor de construcție și de material, începând de la data vânzării lui către utilizator și la simpla prezentare a bonului de casă. Garanția constă în înlocuirea componentelor defecte. Această garanție nu se aplică în cazul exploataării în alt mod decât cel recomandat de normele aparatului și nici în caz de stricăciuni provocate de intervenții neautorizate sau prin neglijența cumpărătorului. Garanția nu se aplică asupra pagbelor cauzate de o defectare a aparatului.

RU. ГАРАНТИЯ

Данное изделие обладает имеющей силу контракта гарантией, покрывающей все возможные дефекты изготовления и материала. Гарантия вступает в силу с даты продажи изделия пользователю, для этого достаточно сохранить и предъявить полученный в кассе чек. Гарантия обязывает изготовителя заменить дефектные части изделия. В случае не соответствующего нормам использования изделия, несанкционированного демонтажа или ремонта или небрежного обращения действие гарантии прекращается. Гарантия не покрывает ущерб, возникшего в результате سوء в работе изделия.

TU. GARANTIA

Bu arac, satís tarihinden itibaren, kullanicinin sádece vezne alindisini sunmasiyá tum úretim ve malzeme hatasina karfi garantilidir. Garanti eksik olan kisimlari degistirmek icindir. Bu garanti aracin sartlarina uygun olmayan isleme durumunda, izin verilmeyen kullanimlarda kaynaklanan hasarlarda veya alcinin istegi durumunda uygulanmaz. Garanti malzemenin bir eksikliginden meydana gelen bir zararda uygulanmaz.

CS. ZÁRUKA

Pro tento nástroj platí smluvní záruka na všechny výrobny a materiálve vady od data prodeje uživatelí a na základě predložení pokladního bloku. Záruka spoívá ve výmene vadných částí. Tato záruka neplatí v prípade použití prístroje, ktoré neodpovídá normám, ani v prípade škod způsobených nepovolenými zásahy nebo nedbalostí ze strany kupujícího. Záruka se nevztahuje na škody způsobené závadou nástroje.

SK. ZÁRUKA

Pre tento nástroj platí zmluvná záruka na všetky výrobne a materiálve chyby od dátumu predaja užívateľovi a na základe predloženia poklad-

ničného bloku. Záruka spoívá vo výmene chybných častí. Táto záruka neplatí v prípade použitia prístroja, ktoré nezodpovedá normám, ani v prípade škod spôsobených nepovolenými zásahmi alebo nedbalosťou zo strany kupujúceho. Záruka sa nevztahuje na škody spôsobené poruchou nástroja

HE. אחריות

הצגת חשבונית קופנה. האחריות-משמעה או בזמרה, החל מיום המכירה למשתמש עם זה חלה אחריות לפי חוזה מבני כל ליקוי בייצור נזק שנגרם על ידי התערבות תללה הי עלכלי במכשיר שאינו מתאים לתקינים ובמקרה של תקליקים הלוקיים אחריות זו אינה חלה במקרה של שימוש על נזק שנגרם על ידי תהלה בכלל. החלפת תהלקם די רשלנות מאת הקונה. האחריות אינה חלה על סמכות או על

AR. الضمان

وبناء على مجرد تقديم بطاقة الشراء في عمل ق إختياراً من تاريخ البيع الى المشتري عمل من أي عيب في التصدي عوفى الجوال. لياتلقات إن مدة العدة خصمودة تعاقديا العطارق لم عايير الجهاز. ول في حالة تعرضه قابلاً للتطبيع في حالة الاستخدام غير استبدال الأجزاء الأعطلة لى يلون مدا الضمان على الصخر الناتج عن خلل الضمان فاي الإبدال من قبل المشتري لى يطبق الضمان عن عمليات تدخل غير مخصصة أو في حالة ناتجة

HU. GARANCIA

Erre a szerszámra szerződéses garanciát vállalunk bármilyen gyártási és anyaghiba felmerülése esetére, a fogvasztó részére történő eladás napjától, számítva, a penztári blokk egyszerű felmutatása ellenében. A garancia a hibás alkatrészek cseréjére terjed ki. Ez a garancia nem érvényes, ha a készüléket nem rendeltetésszerűen használták, sem illetéktelen beavatkozások, vagy a vásárló hanyagsága okozta károk esetén. A garancia nem fedezi azokat a károkat, melyeket a szerszám hibás működése okozott.

SI. GARANCIJA

To orodje je z garancijsko pogodbo zasciteno proti vsem napakam v izdelavi in v sestavnem materialu od datuma prodaje naprej in ta velja ob predložitvi blagajniškega računa. Garancija velja za zamenjavo delov z napako. Ta garancija ne velja za uporabo orodja, ki ni v skladu z normami, predpisanimi za omenjeno orodje in za primere okvar, ki nastanejo zaradi nedovoljenih posegov na orodju ali zaradi malomarnega rokovanja kupca. Garancija ne velja za škodo, ki jo lahko povzročí okvara orodja.

ET. GARANTII

See tööriist kuulub lepingu järgi garantiiremonti arvestades alates müümise päevast ja kassatseki alusel kasutatule koigi konstruktsiooni- ja materjalvigade puhul. Garantii seisneb defektsete osade väljavahetamises. See garantii ei kehti aparadi normide ebatavalise eiramise puhul ega ostja poolt keelatud viisil kasutamisest või hooletussejätmisest tule-

nevate kahjude korral. Garantii ei kehti seadme defektidest põhjustatud kahjude puhul

LV. GARANTĪJA

Šis prietaiss varj uztiikrinamas kaip itin geros kokybės, nuo jo pardaavimo datos iki jo panaudojimo, ir jam yra suteikiamas garantinis talonas. Garantijos metu galima pakeisti atsiradusius trumplataikius gedimus. Si garantija netaikoma esant netinkamam naudojimui ar nesilaikant reikiamų šio aparato vartojimo instrukcijų, tai pat pačiam pirkeiui jį sugadinus. Garantija taip pat netaikoma, prietaiss naudojant ne pagal paskirtį ir jį apgadinus.

LT. GARANTĪJA

Sim darbarikam ir liguma noteikta garantija visiem defektiem, kas saistās ar konstrukciju un materiālu, sakot ar pardosanas datumu, kad mašinu pārdod lietotājam un vienkarši uzradot kases ceku. Garantija iekļauj bojāto daļu nomainu. Si garantija nav derīga, ja aparāts nav lietots saskaņā ar drošības noteikumiem, ne gādijumos ja bojājumi radusies nesankcionētas ierīkšanas gādijumā vai arī pircēja nolaidības dēļ. Garantija nav derīga, ja bojājumi radusies darbarika defekta dēļ

HR. JAMSTVO

Ovaj alat ima ugovorno jamstvo u slučaju bilo kakvih nedostataka u konstrukciji i materijalu, od datuma prodaje korisniku uz jednodavno predocjenje računa. Jamstvo se sastoji u zamjeni neispravnih dijelova. Ovo se jamstvo ne primjenjuje u slučaju uporabe i eksploatacije koja nije sukladna standardima uređaja, niti u slučaju štete uzrokovane neovlaštenim intervencijama ili nedarom kupca. Jamstvo se ne primjenjuje na štetu uzrokovanu nekim nedostatkom alata.

SERVICE APRÈS VENTE - AFTER SALE SERVICE

FARGROUP EUROPE - 192, Avenue Yves Farge - 37700 St. Pierre-des-Corps - FRANCE

fargroup@fargroup.net



FAR GROUP EUROPE

Une société du groupe **SIGMA**

192, Avenue Yves Farge
37700 St. Pierre-des-Corps
FRANCE

www.fartools.com

