

DE	Gebrauchsanleitung / Montageanleitung	2
FR	Mode d'emploi / Instructions de montage	3
EN	Instructions for use / Assembly instructions	4
IT	Istruzioni per l'uso / Istruzioni per Installazione	5
ES	Modo de empleo / Instrucciones de montaje	6
NL	Gebruiksaanwijzing / Handleiding	7
DK	Brugsanvisning / Monteringsvejledning	8
PT	Instruções para uso / Manual de Instalação	9
PL	Instrukcja obsługi / Instrukcja montażu	10
CS	Návod k použití / Montážní návod	11
SK	Návod na použitie / Montážny návod	12
ZH	用户手册 / 组装说明	13
RU	Руководство пользователя / Инструкция по монтажу	14
FI	Käyttöohje / Asennusohje	15
SV	Bruksanvisning / Monteringsanvisning	16
LT	Vartotojo instrukcija / Montavimo instrukcijos	17
HR	Upute za uporabu / Uputstva za instalaciju	18
RO	Manual de utilizare / Instrucțiuni de montare	19
EL	Οδηγίες χρήσης / Οδηγία συναρμολόγησης	20
SL	Navodilo za uporabo / Navodila za montažo	21
ET	Kasutusjuhend / Paigaldusjuhend	22
LV	Lietošanas pamācība / Montāžas instrukcija	23
SR	Uputstvo za upotrebu / Uputstvo za montažu	24
NO	Bruksanvisning / Montasjeveiledning	25
BG	Инструкция за употреба / Ръководство за монтаж	26
JP	取扱説明書 / 施工説明書	27
SQ	Udhëzuesi i përdorimit / Udhëzime rreth montimit	28
AR	دليل الاستخدام / تعليمات التجميع	29
TR	Kullanım kılavuzu / Montaj kılavuzu	30
HU	Használati útmutató / Szerelési útmutató	32

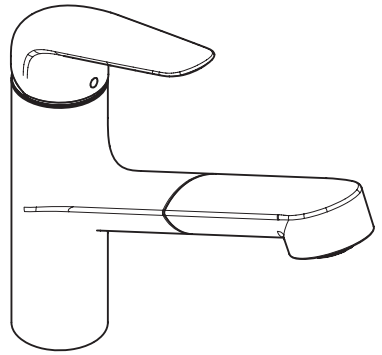

Focus M42 150 1jet

71814XXX

Focus M42 150 1jet Eco

71865000

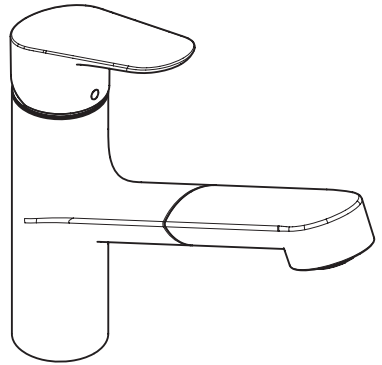

Focus M43 150 1jet

71842XXX



Consignes de sécurité

- ⚠ Lors du montage, porter des gants de protection pour éviter toute blessure par écrasement ou coupure.
- ⚠ Il est conseillé d'équilibrer les pressions de l'eau chaude et froide.

Instructions pour le montage

- Avant son montage, s'assurer que le produit n'a subi aucun dommage pendant le transport. Après le montage, tout dommage de transport ou de surface ne pourra pas être reconnu.
- Les conduites et la robinetterie doivent être montés, rincés et contrôlés selon les normes en vigueur.
- Les directives d'installation en vigueur dans le pays concerné doivent être respectées.
- **71865000:** Le robinet ne fonctionne pas avec une production d'eau chaude instantanée.

Informations techniques

- Pression de service autorisée: max. 1 MPa
 Pression de service conseillée: 0,1 - 0,5 MPa
 Pression maximum de contrôle: 1,6 MPa
 (1 MPa = 10 bar = 147 PSI)
- Température d'eau chaude: max. 60 °C
 Désinfection thermique: 70 °C / 4 min
- Avec dispositif anti-retour
 - Le produit est exclusivement conçu pour de l'eau potable!

Description du symbole



Ne pas utiliser de silicone contenant de l'acide acétique!



Étalonnage (voir pages 36)

Réglage de la limitation d'eau chaude. En liaison avec les chauffe-eau, un blocage de l'eau chaude n'est pas recommandable.



Entretien (voir pages 41)

Les clapets anti-retour doivent être examinés régulièrement conformément à la norme EN 806-5 ou conformément aux dispositions nationales ou régionales quant à leur fonction (au moins une fois par an).



Dimensions (voir pages 38)



Diagramme du débit (voir pages 39)



Pièces détachées (voir pages 42)

XXX = Couleurs
 000 = Chromé
 800 = Aspect Acier Inox

Accessoires en option

(ne fait pas partie de la fourniture)



Adaptateur (G $\frac{3}{8}$ / G $\frac{1}{2}$)
 #93395000 (voir pages 44)



Nettoyage (voir pages 40)



Instructions de service (voir pages 37)

Hansgrohe recommande de ne pas utiliser le premier demi-litre le matin ou après une période de stagnation prolongée.



Classification acoustique et débit (voir pages 35)

Dysfonctionnement	Origine	Solution
Pas assez d'eau	- aérateur entartré ou encrassé	- Nettoyer l'aérateur ou le changer éventuellement
Durété de fonctionnement	- Cartouche défectueuse, entartrée	- Changer la cartouche
Le mitigeur goutte	- Cartouche défectueuse	- Changer la cartouche
Fuite à la fixation sous le mitigeur	- Les flexibles de raccordement ne sont pas correctement vissés dans le corps.	- Resserrer le flexible à la main.
	- Joint torique sous les flexibles de raccordements défectueux	- Changer le joint torique
Température d'eau chaude trop basse, pas d'eau froide	- Limiteur de température mal positionné	- Positionner le limiteur de température

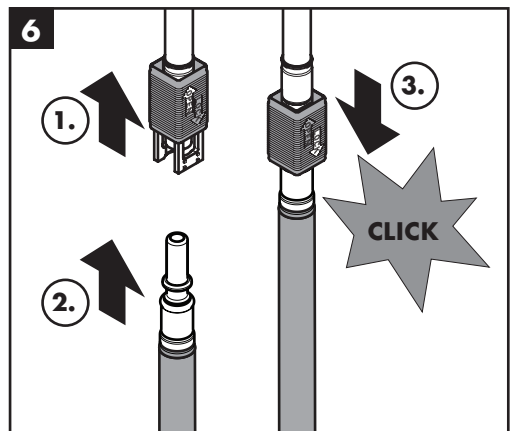
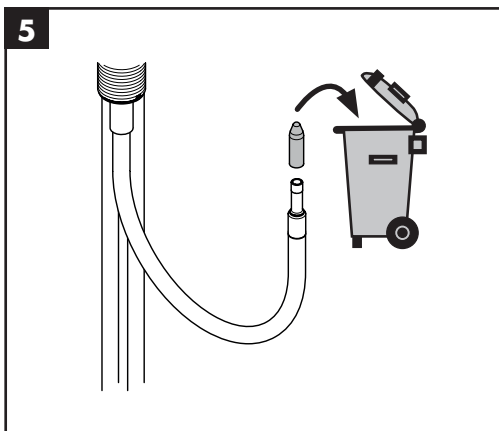
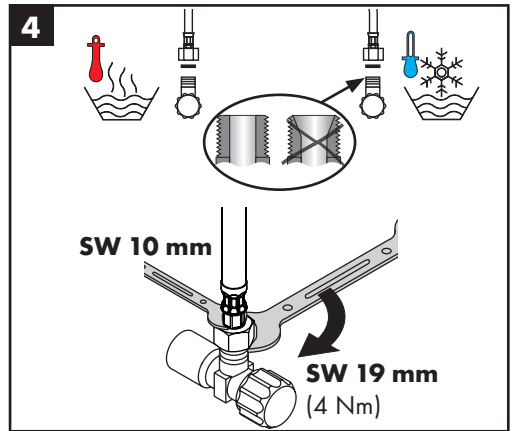
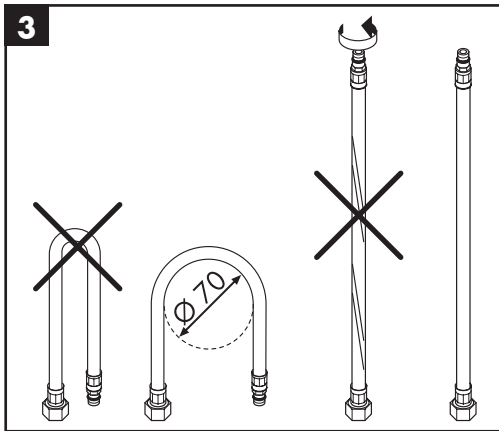
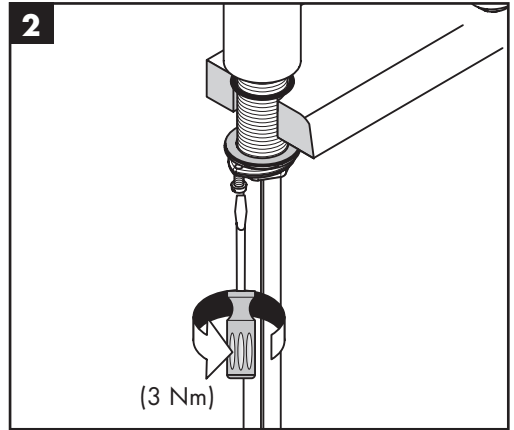
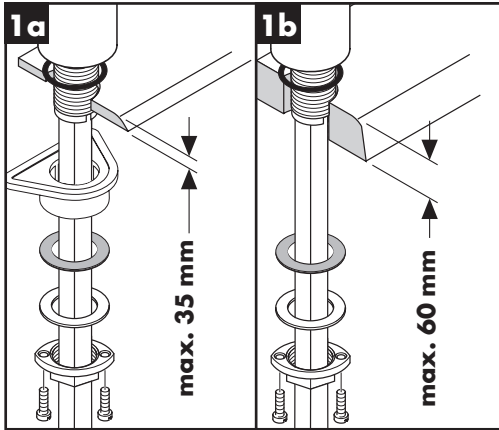

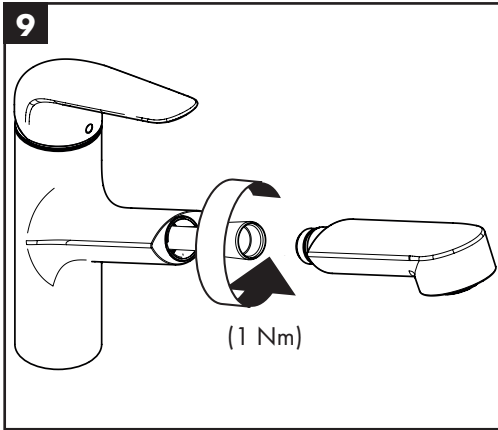
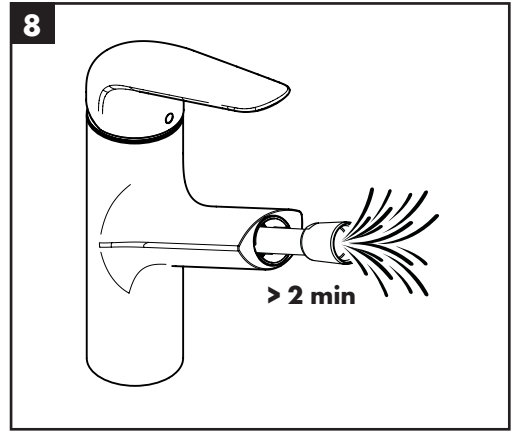
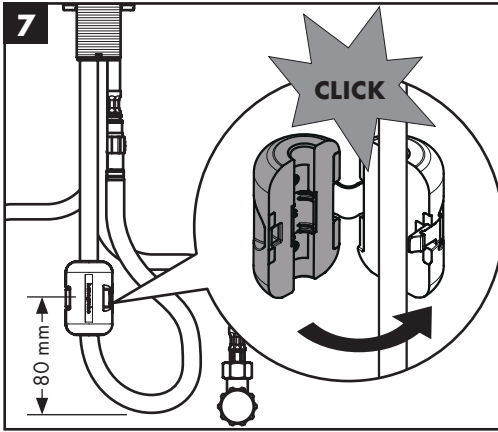

	P-IX	DVGW	SINTEF	NF	STF	SE KIWA CERTIFICATION BODY	ETA
71814XXX	P-IX 7359/IA	CT0436		X		X	
71842XXX	P-IX 7359/IA	CT0435				X	
71865000							



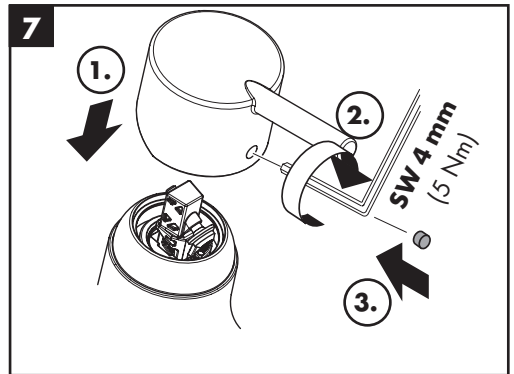
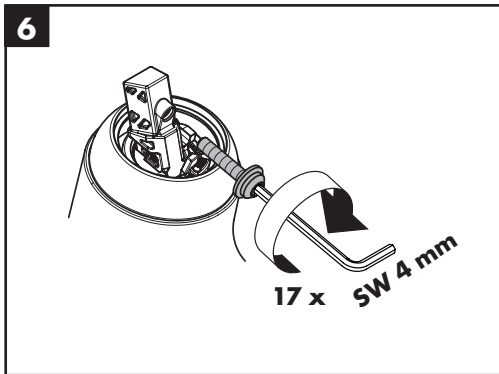
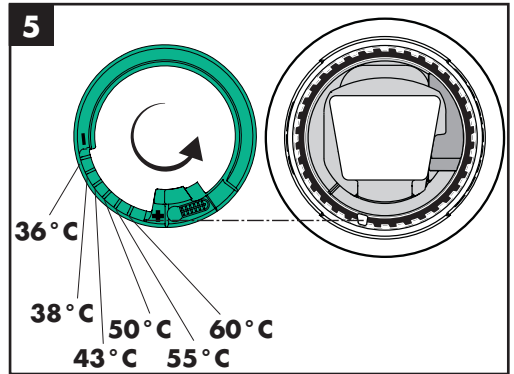
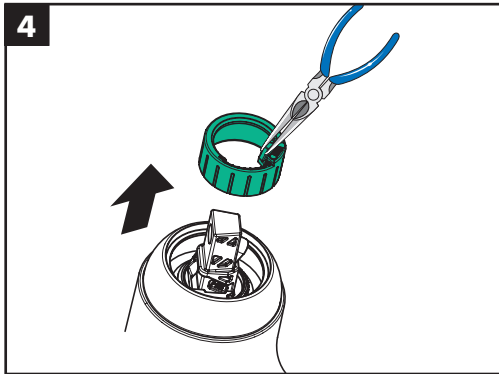
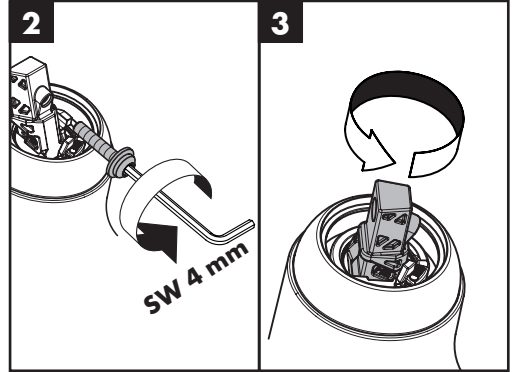
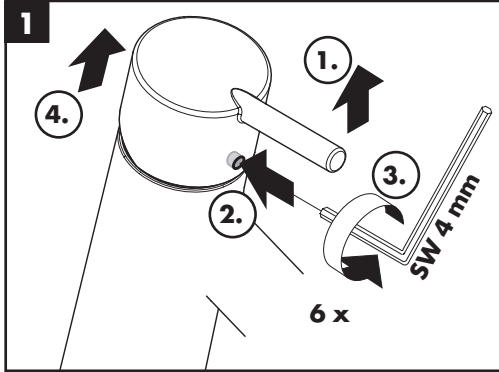



Focus M42 150 1jet

71814XXX

Focus M42 150 1jet Eco

71865000

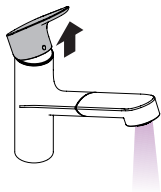

öffnen / ouvert / open / aperto / abierto / open / åbne / abrir / otworzyć / otevřít / otvorit / 开 / открыт / nyitás / avaaminen / öppna / atidaryti / Otvaranje / açmak / deschide / ανοικτό / odpreti / avage / atvērt / otvoriti / åpne / отварање / hape / فتح / 開く

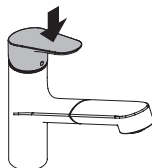

schließen / fermé / close / chiudere / cerrar / sluiten / lukke / fechar / zamknąć / zavřít / uzavriť / 关 / закрыть / bezárás / sulkeminen / stänga / uždaryti / Zatvaranje / kapatmak / închide / κλειστό / zapreti / sulgege / aizvērt / zatvori / lukke / затваряње / mbylle / إغلاق / 閉じる

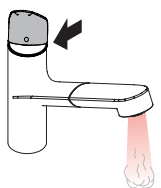

warm / chaud / hot / caldo / caliente / warm / varmt / quente / ciepła / teplá / teplá / 热 / горячая / meleg / lämmin / varmt / karštas / Vruća voda / sıcak / cold / ζεστό / toplo / kuum / karsts / topla / varm / топло / i ngrohtë / ساخن / 温かい

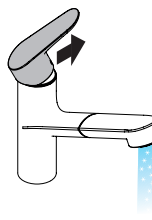

kalt / froid / cold / freddo / frío / koud / koldt / fria / zimna / studená / studená / 冷 / холодная / hideg / kylmä / kallt / šaltas / Hladno / soğuk / rece / krūo / mrzlo / külm / auksts / hladno / kaldt / студено / i ftohtë / بارد / 冷たい

Focus M43 150 1jet

71842XXX

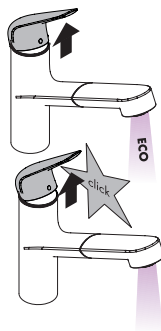

öffnen / ouvert / open / aperto / abierto / open / åbne / abrir / otworzyć / otevřít / otvorit / 开 / открыт / nyitás / avaaminen / öppna / atidaryti / Otvaranje / açmak / deschide / ανοικτό / odpreti / avage / atvērt / otvoriti / åpne / отварање / hape / فتح / 開く

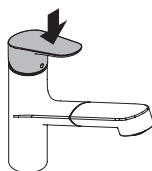

schließen / fermé / close / chiudere / cerrar / sluiten / lukke / fechar / zamknąć / zavřít / uzavriť / 关 / закрыть / bezárás / sulkeminen / stänga / uždaryti / Zatvaranje / kapatmak / închide / κλειστό / zapreti / sulgege / aizvērt / zatvori / lukke / затваряње / mbylle / إغلاق / 閉じる

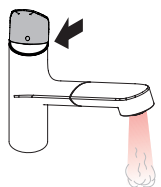

warm / chaud / hot / caldo / caliente / warm / varmt / quente / ciepła / teplá / teplá / 热 / горячая / meleg / lämmin / varmt / karštas / Vruća voda / sıcak / cold / ζεστό / toplo / kuum / karsts / topla / varm / топло / i ngrohtë / ساخن / 温かい

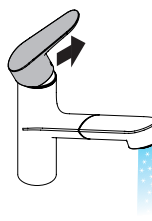

kalt / froid / cold / freddo / frío / koud / koldt / fria / zimna / studená / studená / 冷 / холодная / hideg / kylmä / kallt / šaltas / Hladno / soğuk / rece / krūo / mrzlo / külm / auksts / hladno / kaldt / студено / i ftohtë / بارد / 冷たい



Focus M42 150 1jet

71814XXX

Focus M42 150 1jet Eco

71865000

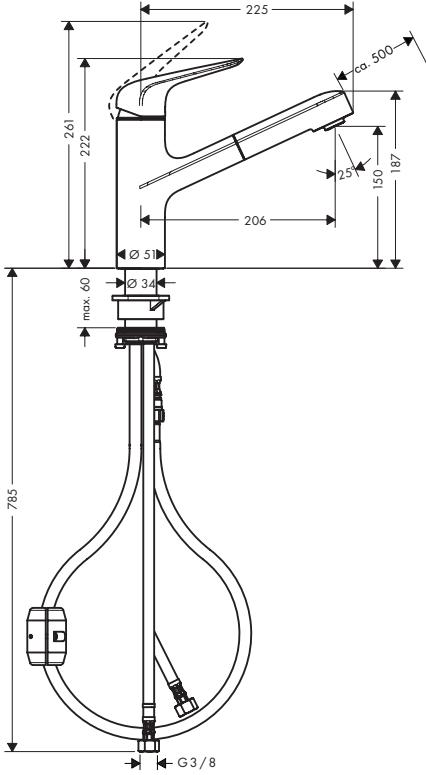

Focus M43 150 1jet

71842XXX

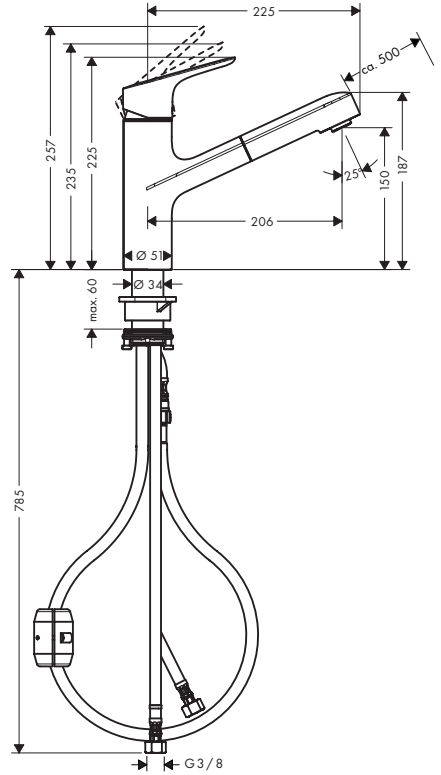



Focus M42 150 1jet

71814XXX

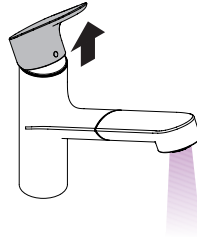
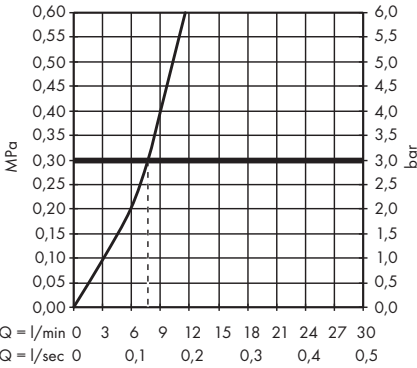

Focus M43 150 1jet

71842XXX

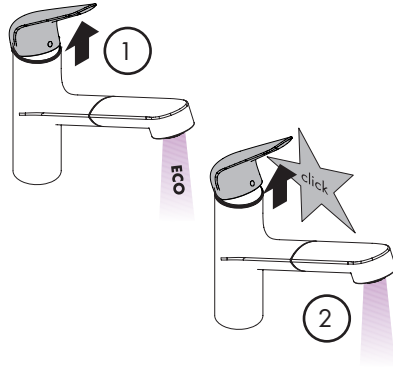
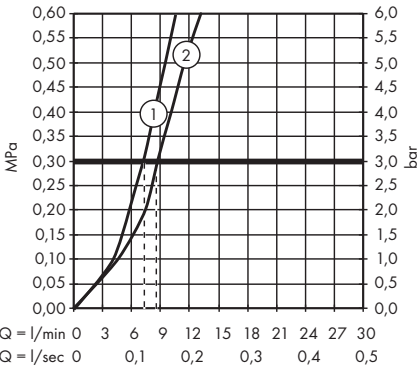

Focus M42 150 1jet Eco

71865000

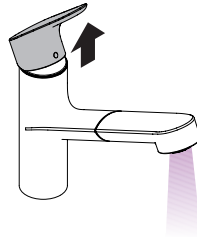
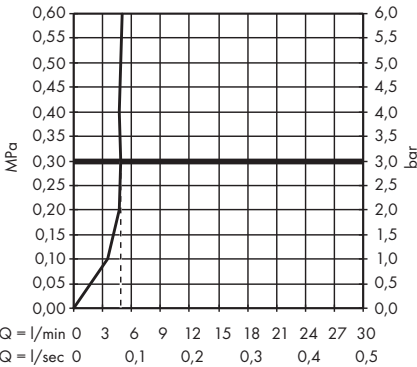



- DE** Reinigungsempfehlung / Garantie / Kontakt
- FR** Recommandation pour le nettoyage / Garanties / Contact
- EN** Cleaning recommendation / Warranty / Contact
- IT** Raccomandazione di pulizia / Garanzia / Contatto
- ES** Recomendaciones para la limpieza / Garantía / Contacto
- NL** Aanbevelingen inzake reiniging / Garantie / Contact
- DK** Rengøringsvejledning / Garanti / Kontakt
- PT** Recomendações de limpeza / Garantia / Contacto
- PL** Zalecenie dotyczące pielęgnacji / Gwarancja / Kontakt
- CS** Doporučení k čištění / Záruka / Kontakt
- SK** Odporúčania pre čistenie / Záruka / Kontakt
- ZH** 清洁指南 / 担保 / 接触
- RU** Рекомендации по очистке / Гарантия / Контакты
- FI** Puhdistussuositus / Takuu / Kosketus
- SV** Rengöringsrekommendationer / Garanti / Contacto
- LT** Valymo rekomendacijos / Garantija / Kontaktai
- HR** Preporuke za čišćenje / Garancija / Kontakt
- TR** Temizleme önerisi / Garanti / Temas
- RO** Recomandări pentru curățare / Garanție / Contact
- EL** Σύσταση καθαρισμού / Εγγύηση / επαφή
- SL** Priporočilo za čiščenje / Garancija / Kontakt
- ET** Puhastussoovitused / Garantii / Kontakt
- LV** Tīrīšanas ieteikumi / Garantija / Kontakti
- SR** Preporuke za čišćenje / Garancija / Kontakt
- NO** Anbefaling for rengjøring / Garanti / Kontakt
- BG** Препоръка за почистване / Гаранция / Контакт
- SQ** Këshilla rreth pastrimit / Garancia / Kontakt
- KO** 세정시 권장사항 / 품질보증 / 접촉
- AR** توصيات التنظيف / الضمان / اتصال
- HU** Tisztítási tanácsok / Garancia / érintkezés
- JP** お手入れの方法 / 保証について / ご連絡先



[www.hansgrohe.com/
cleaning-recommendation](http://www.hansgrohe.com/cleaning-recommendation)

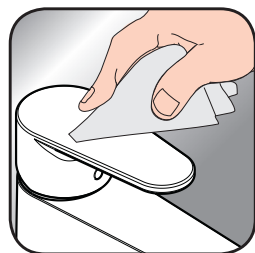

[www.hansgrohe.com/
cleaning-recommendation](http://www.hansgrohe.com/cleaning-recommendation)



[www.hansgrohe.com/
cleaning-recommendation](http://www.hansgrohe.com/cleaning-recommendation)



[www.hansgrohe.com/
cleaning-recommendation](http://www.hansgrohe.com/cleaning-recommendation)

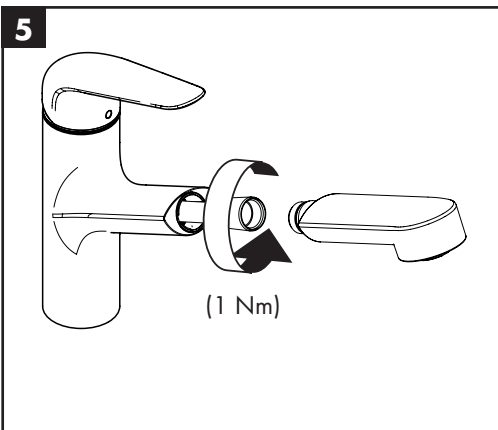
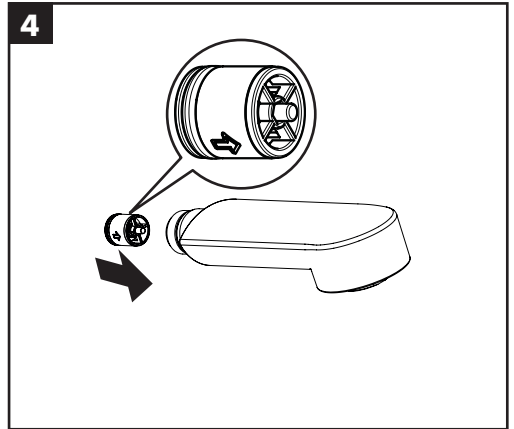
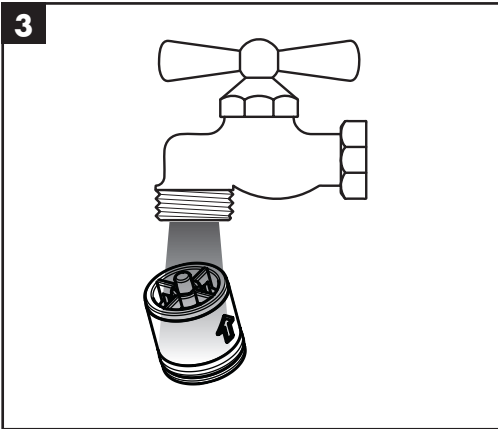
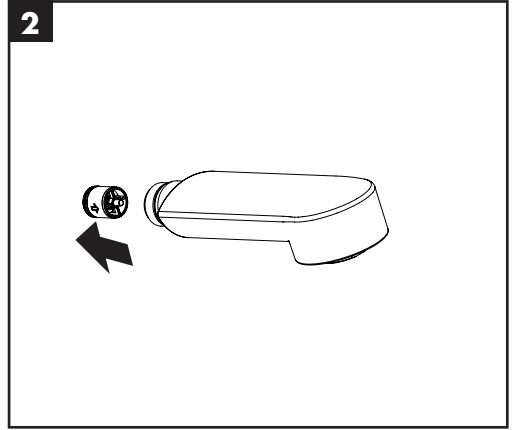
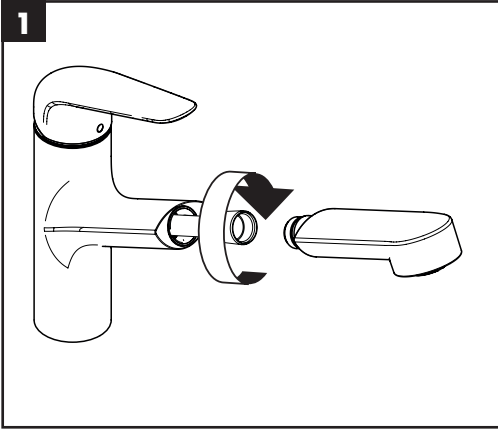

Focus M43 150 1jet
71842XXX

