

MFE1500B RAINUREUSE MURALE 1500W-1

4935385840 - MFE1500/0 - 4000385841

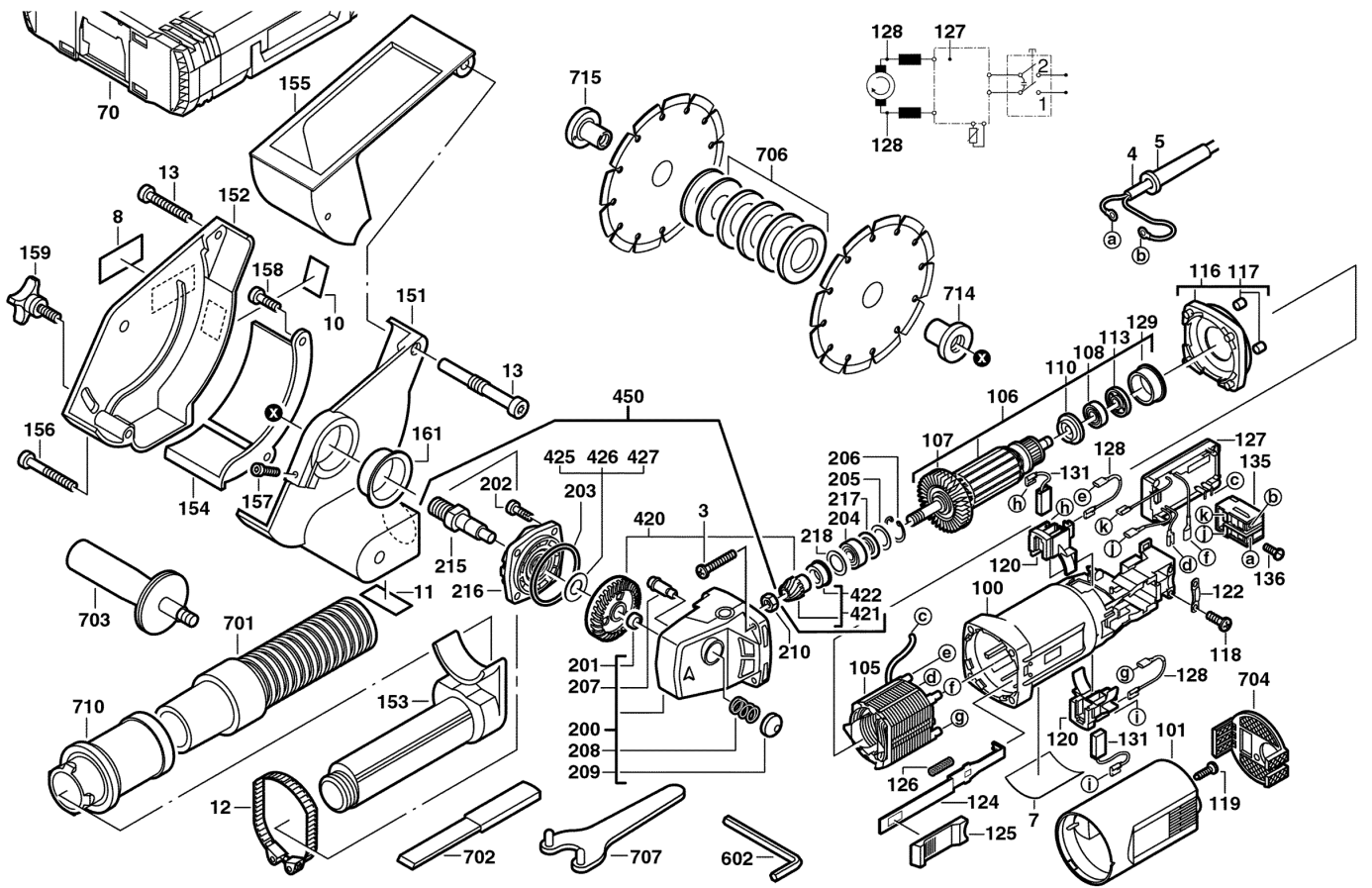



Position	Quantité	Désignation	Référence	EAN
0003	4	VIS	4931621515	4002395695508
0004	1	CABLE D"ALIMENTATI.	4931623861	4002395704293
0005	1	GAINE DE CABLES	4931218785	4002395583805
0007	1	PLAQUE SIGNALETIQUE	4931385846	4002395721269
0008	1	PLAQUE DU CONSTRUC.	5131000000	
0010	1	PLAQUE	4931334659	4002395616305
0011	1	PLAQUE	4931334660	4002395616312
0012	1	ETRIER DE RETENUE	4931334664	4002395616329
0013	1	ROULETTE	4931449440	4002395258611
0070	1	COFFRET D.TRANSPORT	5131000000	
0100	1	CARTER	4931412699	4002395793457
0101	1	CHAPEAU DE CARTER	4931412698	4002395793440
0105	1	CHAMP ELECTRIQUE	4931426582	4002395845101
0106	1	INDUIT	4931426545	4002395846245
0107	1	VENTILATEUR	4931341088	4002395626205
0108	1	ROULEMENT A BILLES	4931624662	4002395790890
0110	1	DISQUE ISOLATEUR	4931271823	4002395588138
0113	1	DISQUE MAGNETIQUE	4931426570	4002395856497
0116	1	BRIDE INTERMEDIAIRE	4931362611	4002395661237
0117	2	MANCHE	4931409768	4002395847617
0118	2	VIS	4931624538	4002395760039
0119	1	VIS	4931619914	4002395695225
0120	2	PORTE-BALAIS	4931326923	4002395607778
0122	1	BRIDE	4931256500	4002395586547
0124	1	PIECE INTERMEDIAIRE	4931326959	4002395607877
0125	1	COULISSEAU	4931442821	4002395254293
0126	1	RESSORT DE PRESSION	4931326981	4002395607945
0127	1	PLATIN.ELECTRONIQUE	4931362699	4002395661398
0128	2	CABLE	4931623738	4002395703692
0129	1	COUSSINET	4931326953	4002395607846
0131	1	SET DE CHARBONS	4931369477	4002395673476
0135	1	INTERRUPTEUR	4931326976	4002395607938
0136	2	VIS	4931617313	4002395694761
0151	1	COUVERTURE D"ASPIR.	4931413634	4002395841554
0152	1	CAPOT PROTECTEUR	4931413635	4002395841561
0153	1	CONNECTION	4931476111	4058546342517
0154	1	DEFLECTEUR	4931334711	4002395616367
0155	1	DEPLACEMENT VERTIC.	4931476113	4058546342531
0156	1	VIS	4931622927	4002395699728
0157	1	VIS	4931622928	4002395699735
0158	2	VIS	4931617290	4002395694747
0159	1	POIGNEE	4931334713	4002395616381
0161	1	DOUILLE ISOLANTE	4931362742	4002395661473
0200	1	CARTER D"ENGRENAGE	4931412193	4002395798919
0201	1	DOUILLE	4931912093	4002395706464
0202	4	VIS	4931317532	4002395600175
0203	1	RONDELLE D.COMPENS.	4931254894	4002395586448
0204	1	ROULEMENT A BILLES	4931368037	4002395670642
0205	1	DISQUE	4931622761	4002395699056
0206	1	CIRCLIP	4931616614	4002395694624

Position	Quantité	Désignation	Référence	EAN
0207	1	BOULON D"ARRET	4931326929	4002395607785
0208	1	RESSORT DE PRESSION	4931326942	4002395607822
0209	1	LOQUET	4931326930	4002395607792
0210	1	ECROU	4931326952	4002395607839
0215	1	BROCHE	4931409809	4002395838691
0216	1	PLAQUE DE ROULEMENT	4931385801	4002395720705
0217	1	RONDELLE	4931624287	4002395732098
0218	1	RONDELLE	4931362085	4002395660254
0420	1	ROUE CONIQUE COMPL.	4931369887	4002395674398
0421	1	PIGNON	4931369887	4002395674398
0422	1	GARNITURE	4931369774	4002395674169
0425	1	DISQUE	4931808473	4002395727544
0426	1	DISQUE	4931925940	4002395706624
0427	1	DISQUE	4931624256	4002395723379
0450	1	ENTRAINEMENT	4931391477	4002395735891
0602	1	CLE SIX PANS	4931616056	4002395694501
0706	1	KIT D"ESPACEMENT MFE1305 (x1)	4931334675	4002395762804
0702	1	BURIN POUR MFE	4932367197	
0703	1	POIGNEE LATERALE MEUL 180/2300MM (X1)	4932409546	4002395370870
0704	1	FILTRE POUSSIERES WCE30/WCS45 (X1)	4932329397	4002395303892
0707	1	CLE POUR ECROU A30 (x1)	4932345712	4002395305551
0710	1	ADAPTATEUR ASPIRATEUR (X1)	4932362778	4002395334285
0714	1	ECROU DE SERRAGE MFE 1305 (X1)	4932334706	4002395304455
0715	1	ECROU DE SERRAGE DME 1300 (X1)	4932334667	4002395304448