

# DAVIS SENSOR

APP.EXT.E27.DAVIS.FLB.SEN.ANT

CODE COREP : 653732

EAN 13 :



3 188000 753762



Rue Radio-Londres  
CS50001 - 33323 BÈGLES CEDEX (FRANCE)  
France : contactpro@corep.com  
Export : export@corep.com  
www.corep.com

Coloris : anthracite E27 - 20W

Color : anthracite

Description : Applique forme flambeau en acier inoxydable. Equipée d'un détecteur de présence.

*Stainless steel torch wall light.*

*Delivered with sensor system.*

AMPOULE  
CONSEILLÉE  
Suggested bulb



T45  
654317  
10551



3 188000 760104

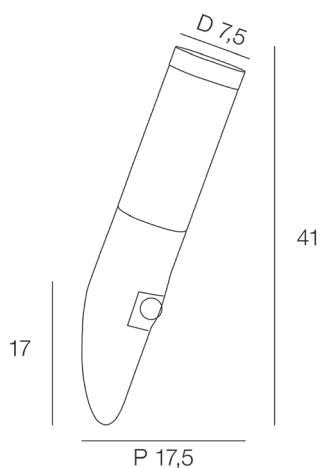

POIDS NET/NET WEIGHT : 400 gr

COLIS 1 COLOR\_BOX

L8xP8xH41 cm

POIDS BRUT/GROSS WEIGHT : 500 gr

