

CHELSEA

APP.EXT.E27.CHELSEA.NOI

CODE COREP : 653722

EAN 13 :



Rue Radio-Londres
CS50001 - 33323 BÈGLES CEDEX (FRANCE)
France : contactpro@corep.com
Export : export@corep.com
www.corep.com

Coloris : noir

E27 - 40W

Color : black

Description : Applique montante en polycarbonate avec cache ampoule en polycarbonate opale.

Uplight polycarbonate wall lamp with opal polycarbonate socket.

AMPOULE
CONSEILLÉE
Suggested bulb



A60
654310
10550

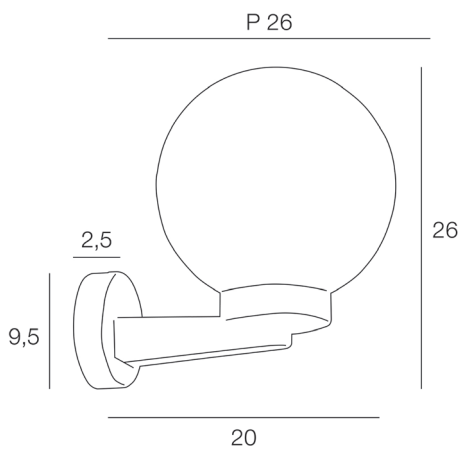

POIDS NET/NET WEIGHT : 345 gr

COLIS 1 COLOR_BOX

L27xP26,50xH21 cm

POIDS BRUT/GROSS WEIGHT : 575 gr

