

# DAVIS

APP.EXT.E27.DAVIS.FLB.ANT

CODE COREP : 653730

EAN 13 :



3 188000 753748



Rue Radio-Londres  
CS50001 - 33323 BÈGLES CEDEX (FRANCE)  
France : [contactpro@corep.com](mailto:contactpro@corep.com)  
Export : [export@corep.com](mailto:export@corep.com)  
[www.corep.com](http://www.corep.com)

Coloris : anthracite E27 - 20W

Color : anthracite

Description : Applique forme flambeau en acier inoxydable.

*Stainless steel torch wall light.*

AMPOULE  
CONSEILLÉE  
Suggested bulb



T45  
654317  
10551



3 188000 760104

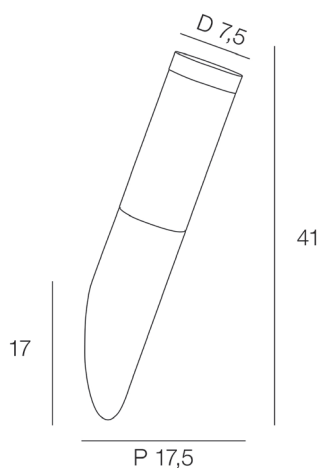

POIDS NET/NET WEIGHT : 345 gr

COLIS 1 COLOR\_BOX

L8xP8xH41 cm

POIDS BRUT/GROSS WEIGHT : 440 gr

