

PIXEL

APP.E27.L17.VER.PIXEL.OPA

CODE COREP : 512119

EAN 13 :  3 188000 635846



Rue Radio-Londres
CS50001 - 33323 BÈGLES CEDEX (FRANCE)
France : contactpro@corep.com
Export : export@corep.com
www.corep.com

Coloris : opale blanc E27 - 60W

Color : white opal

Description : Applique 1/2 lune en verre imprimé couleur.

Colored glass half shade wall light.

AMPOULE
CONSEILLÉE
Suggested bulb



A60
654309
10550

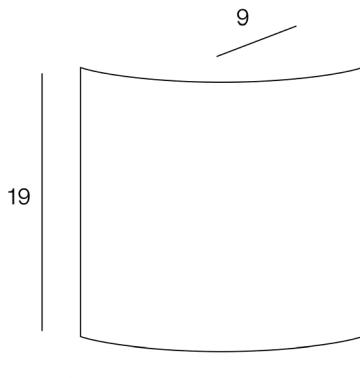

17



POIDS NET/NET WEIGHT : 440 gr

COLIS 1 COLOR_BOX

L21,50xP11xH24 cm

POIDS BRUT/GROSS WEIGHT : 590 gr

