



MAKE IT WONDERFUL

FRANKE

MALTA FRAGRANIT+

Fiche Technique

MALTA 621

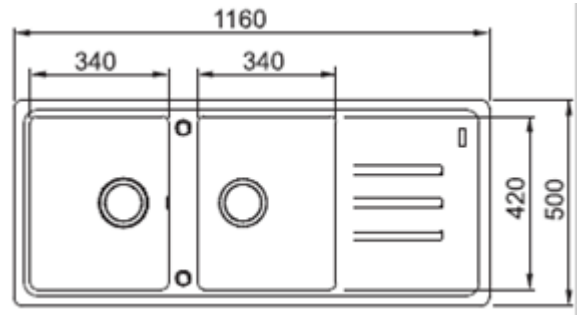
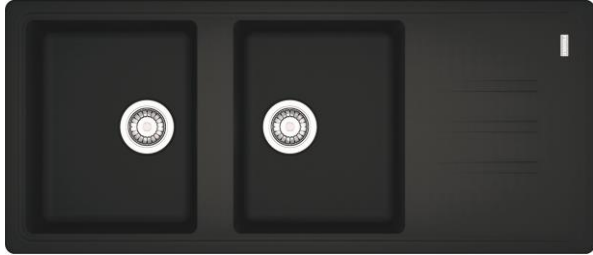

Dimensions : 1160 x 500 mm
Découpe : 1140 x 480 mm
Bassins : 2 x 337 x 420 x 206 mm
Caisson : 800 mm



A encastrer



Garantie 10 ans
Fragranit +



Vidage gain de
place avec bonde \varnothing
90mm et siphon



Traitement
antibactérien



Eviers pré-perçés \varnothing 35 mm pour
robinetterie
Utilisez une pointe et un marteau



MALTA 621

Emballage individuel.
Spécifications techniques modifiables sans préavis – 1115

