

# HONU D48

SUSP.E27.MET.HONU.D48.NOI

CODE COREP : 657549

EAN 13 :



Rue Radio-Londres  
CS50001 - 33323 BÈGLES CEDEX (FRANCE)  
France : contactpro@corep.com  
Export : export@corep.com  
www.corep.com

Coloris : noir/naturel E27 - 15W

Color : black/natural

Description : Suspension forme capeline en métal perforé. Équipée d'un cordon avec cache douille effet bois.

Pendant light capeline shape in perforated metal. Equipped with a cord and a wood effect socket cover.

AMPOULE  
CONSEILLÉE  
Suggested bulb



G80  
654322  
10507

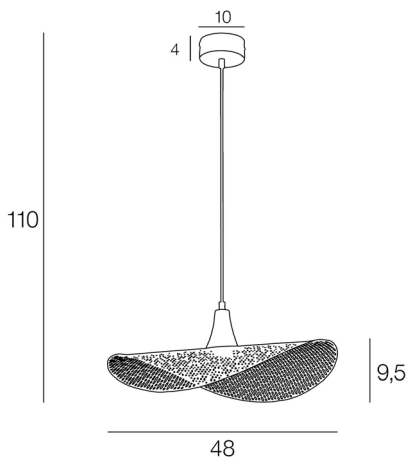

POIDS NET/NET WEIGHT : 1046 gr

COLIS 1 COLOR BOX

L44xP11,50xH49,50 cm

POIDS BRUT/GROSS WEIGHT : 1800 gr

